

# Farm Works Mate Programs *Reference Guide*

*Version 12.0 and higher*

**Farm Works Software®** is a division of

CTN Data, LLC

6795 S. State Road 1

P.O. Box 250

Hamilton, IN 46742-0250

Phone (Sales): 1.800.225.2848

Phone (Technical Support): 1.260.488.3492

Fax: 1-260-488-3737

E-mail: [farmwork@farmworks.com](mailto:farmwork@farmworks.com)

Website: [www.farmworks.com](http://www.farmworks.com)

Project Managers..... R. Scott Nusbaum, Deb Hurraw

Editors..... Deb Hurraw, Jeff Geiger

Technical Writer..... Jake Walker

Desktop and Electronic Publisher..... Jake Walker, Nicole Gregg

Research Consultants..... Tony Bowers, Kathy Cline, Jeff Geiger

*Special Thanks to the dedicated professionals at Farm Works Software who helped make this publication possible.*

## Farm Works Mate X2 Reference Guide

### **COPYRIGHT INFORMATION**

FEDERAL COPYRIGHT LAW PROTECTS THIS SOFTWARE. COPYING THE SOFTWARE FOR ANY REASON OTHER THAN TO MAKE A BACKUP IS A VIOLATION OF LAW. INDIVIDUALS WHO MAKE UNAUTHORIZED COPIES MAY BE SUBJECT TO CIVIL AND CRIMINAL PENALTIES.

Farm Trac X2 Reference Guide (Version 12.0 and higher for Microsoft® Windows® Operating Systems) copyright© 2006 Farm Works Software®, a division of CTN Data, LLC. All rights reserved. This document is the property of Farm Works Software. This document, as well as the software described in it, are furnished under license and may only be used in accordance with the terms of such license. Except as permitted by such license, no part of this document may be reproduced, stored in a retrieval system, or transmitted by any means, electronic, mechanical, photocopying, recording, or otherwise, without written permission from Farm Works Software®. All use, disclosure, and/or reproduction not specifically authorized by Farm Works Software® are prohibited.

The information in this document is provided for reference only. Although every precaution has been made to make the material herein as complete and accurate as possible, no warranty or fitness is implied, nor is any liability assumed for errors or omissions. The information provided is on an "as-is" basis. Farm Works Software®, CTN Data, LLC, and the creators of this document shall have neither liability nor responsibility to any person or entity with respect to any loss or damages arising from the information contained herein or from the use of the CD or programs accompanying it. Neither is any patent liability assumed with respect to the use of the information contained in this document.

All terms mentioned in this document that are known to be trademarks, registered trademarks, or service marks have been appropriately capitalized. Farm Works Software and CTN Data, LLC cannot attest to the accuracy of this information. Use of a term in this document should not be regarded as affecting the validity of any trademark, registered trademark, or service mark.

Farm Works Software, copyright© 1992-2006, is a registered trademark of CTN Data, LLC All rights reserved.

### **SOFTWARE LICENSE AND LIMITED WARRANTY**

LICENSE: THIS SOFTWARE IS LICENSED UNDER THE FOLLOWING TERMS AND CONDITIONS, CONTINUING WITH THIS INSTALLATION INDICATES THAT YOU HAVE READ AND UNDERSTAND THIS SOFTWARE LICENSE AND LIMITED WARRANTY AND THAT YOU AGREE TO THESE TERMS AND CONDITIONS. IF YOU DO NOT AGREE TO ANY OF THEM, IMMEDIATELY RETURN THE PACKAGE FOR A REFUND.

CTN Data, LLC (CTN) grants you a personal, non-exclusive, non-transferable license to use the enclosed software and user manual, ("Software") in accordance with the terms of this license. Title to and all rights in the Software remain with CTN. You agree to protect the Software against unauthorized use and disclosure. You will not copy the Software or any part thereof for any reason other than for backup purposes. Modifying of this Software in any way is strictly prohibited without the expressed written consent of CTN. You may not disclose, transfer, or otherwise make available the Software, in any form, to anyone without the prior written consent of CTN.

TERM: This license is effective upon opening the package, and shall automatically terminate if you breach any of the terms and conditions herein. Upon such breach, you agree to destroy all copies of the Software and discontinue use thereof.

Limited Warranty: The Software is sold "AS IS". You assume the entire risk as to the selection, result, and performance of the Software. However, CTN warrants the magnetic diskette or CD on which the Software is recorded to be free from defect in material and workmanship under normal use for a period of ninety (90) days from the date of original purchase. Upon proof of purchase, CTN will replace a defective diskette or CD at no cost, (except for the cost of shipping, which will be paid by the Purchaser). YOUR SOLE AND EXCLUSIVE REMEDY IN THE EVENT OF DEFECT IS EXPRESSLY LIMITED TO REPLACEMENT OF THE DISKETTE OR CD, provided that the diskette or CD has not been abused in any way.

THIS LIMITED WARRANTY CONSTITUTES YOUR SOLE AND EXCLUSIVE REMEDY AND THE SOLE AND EXCLUSIVE LIABILITY OF CTN AND IS IN LIEU OF ALL OTHER WARRANTIES, EXPRESS, IMPLIED, OR STATUTORY, INCLUDING, BUT NOT LIMITED TO, ANY IMPLIED WARRANTY OR MERCHANTABILITY OR FITNESS FOR A PARTICULAR PURPOSE AND ALL OTHER OBLIGATIONS OR LIABILITIES OF SELLER. IN NO CASE IS CTN LIABLE FOR SPECIAL, INCIDENTAL, CONSEQUENTIAL OR INDIRECT DAMAGES OR FOR LOST DATA.

You may not sublicense, assign or transfer this license, the program or the related documentation, and any attempt to do so is void. This agreement is governed by the laws of the State of Indiana, where any claims arising hereunder shall be litigated. This agreement is for a license of intellectual property, and not for the sale of goods (even though some tangible items may be provided) and not governed by the Uniform Commercial Code.

YOU ACKNOWLEDGE THAT YOU HAVE READ THIS AGREEMENT, UNDERSTAND IT AND AGREE TO BE BOUND BY ITS TERMS AND CONDITIONS. YOU FURTHER AGREE THAT IT IS THE COMPLETE AND EXCLUSIVE STATEMENT OF THE AGREEMENT BETWEEN US WHICH SUPERSEDES ANY PROPOSAL OR PRIOR AGREEMENT, ORAL OR WRITTEN, AND ANY OTHER COMMUNICATIONS BETWEEN US RELATING TO THE LICENSING OF SOFTWARE FROM CTN.

## Farm Works Mate X2 Reference Guide

<b>Farm Works Mate Programs.....</b>	<b>1</b>
Overview of the Mate Programs .....	5
Trac Mate Overview.....	5
Site Mate Overview.....	6
Basic Farm Site Mate Module .....	6
Scouting and Sampling Module.....	7
Variable Rate Control Module.....	7
Guide Mate Overview .....	7
<b>Using a Windows™ CE Device.....</b>	<b>8</b>
Creating a partnership between the CE device and the desktop computer / laptop.....	8
Re-setting the CE Device .....	9
<b>Getting Started.....</b>	<b>10</b>
Installing the Farm Works Mate Programs.....	10
Installation Procedures .....	10
Registering Your Software .....	11
<b>Synchronizing Data.....</b>	<b>12</b>
Synchronizing between Trac Mate and Farm Trac+ (or Site Pro).....	12
Synchronization Process.....	12
Linking New Information .....	14
Synchronizing between Site Mate and Farm Site (or Site Pro) .....	16
To synchronize Site Mate log files:.....	16
Saving Information and Preventing Data Loss .....	18
Viewing Data after Synchronization.....	19
Trac Mate.....	19
Site Mate.....	19
<b>Configuring the Mate Programs.....</b>	<b>20</b>
Settings .....	21
Measurement System.....	21
Coordinate System .....	21
GPS Settings .....	21
Errors and Warnings.....	24
Exporting Log Files.....	24
Database Templates.....	25
Pick Lists .....	27
Variable Rate Setup.....	28
Advanced VRA Options.....	29
Logging.....	31
Auto Logging .....	31
Sample IDs.....	31
Offset .....	32
Display.....	32
Current Position .....	32
Grid.....	32
Indicators .....	33
Boundary.....	33
Path.....	33

## Farm Works Mate X2 Reference Guide

Points .....	34
Background .....	34
Advanced .....	34
Advanced Logging Options .....	34
Laser Range Finder .....	35
Tilt Compensation .....	35
Trac Mate.....	35
Guide Mate .....	35
Indicator.....	35
Lightbar.....	36
Headlands.....	36
Micro-Guide.....	37
<b>Using Farm Trac Mate (without Site Mate).....</b>	<b>37</b>
Selecting a Project.....	37
New Job Screen.....	38
Job Setup Screen .....	38
The Job Tab .....	41
Adding/Removing items from a current job .....	43
Entering Harvest Data with Scale Tickets .....	43
Entering Yield Data without Scale Tickets.....	44
Finishing a Job .....	45
Unfinished Jobs / Workorders .....	46
Opening an Unfinished Job / Workorder.....	46
<b>Using Trac Mate (with Site Mate) .....</b>	<b>47</b>
<b>Using Site Mate .....</b>	<b>48</b>
Tools and Indicators .....	48
Job Tab .....	49
Map Tab.....	50
Data Tab .....	51
Scouting Job.....	51
Loading Background Files.....	52
Manual Logging.....	52
Automatic Logging .....	53
Other Site Mate Basic Features.....	54
Grid Sampling .....	54
Manual Location Entry .....	55
Other Site Mate Scouting Features .....	56
Navigate to Point.....	56
<b>Performing a New Sensor Job .....</b>	<b>56</b>
<b>Performing a VRA Job .....</b>	<b>58</b>
<b>Using Guide Mate.....</b>	<b>59</b>
Swath Patterns.....	62
<b>Troubleshooting .....</b>	<b>70</b>
Troubleshooting Your GPS Receiver and Site Mate .....	70
<b>VRA Controller Setup.....</b>	<b>74</b>
Supported Controller Types.....	74

## ***Overview of the Mate Programs***

Farm Works Mate programs work with hand held PCs running the Windows™ CE or Pocket PC™ operating systems, as well as laptops, the Titan RT, and Titan RH. Farm Site Mate works with a GPS receiver for mapping, scouting, and controlling many commonly used variable rate applicators. Guide Mate also works with a GPS receiver to give you parallel guidance on the screen of your device. By combining Site Mate, Trac Mate, and Guide Mate, farm producers finally have a low cost solution to meet all of their needs on one device.

### ***Trac Mate Overview***

Farm Trac Mate works with Farm Trac+ and Site Pro to provide you with the ability to enter crop and chemical records while in the field. Trac Mate includes the following features:

- Works with Farm Trac+ and Site Pro so information, such as field names, equipment, personnel, and supplies, may be downloaded from your desktop computer and into Trac Mate.
- Includes an easy to use configuration process for adding new fields, personnel, equipment, and supplies while away from your desktop computer.
- An integrated time clock can calculate hours worked by each person on an operation.
- Use the on-screen keyboard or the handwriting features of Pocket PCs to enter information. Trac Mate has been designed to minimize the amount of required data entry. Most information is easily entered by selecting items from a list of choices on the screen.
- Use the metered feature to keep track of items such as tach hours. Simply enter the meter reading at the start of the operation and again after the operation is completed. Trac Mate will calculate the amount used on this operation as well as default the starting value for the next operation.
- Detect possible calibration problems in the field by entering the total quantity of each supply used and have Trac Mate calculate the actual rate applied for each supply.
- Record Field and Weather conditions at the time of application for required chemical reporting.

## Farm Works Mate X2 Reference Guide

- Use the Notes area to enter information such as observations about broken tiling, weed or insect problems, or anything that will help you to manage your farm more efficiently.
- Updates permanent records by simply plugging the device into your desktop computer (or swapping the usb drive on a Titan RT) and starting the synchronization process from Farm Trac+ or Site Pro. All of your field histories, EPA records, and enterprise statements will be updated. If you are using Farm Fund\$, this will even update your supply inventories.
- Trac Mate can also be used in conjunction with Site Mate and Guide mate to give even more functionality and you won't even know you are running more than one program!

### **Site Mate Overview**

Farm Site Mate offers three integrated modules for basic mapping, scouting, and variable rate control. The program works with ArcView Shape Files so that data can be used with any geographic information system (GIS) program.

### **Basic Farm Site Mate Module**

- Displays multiple layers of ArcView Shape Files for location reference.
- Maps wet holes, weed and insect infestations, and other areas of interest.
- Allows you to drive around the field and generate an accurate map of field boundaries.
- Logs the locations of soil samples and other important points in the field.
- Allows you to offset logged paths and boundaries for when you cannot drive right on the item being mapped.
- Includes easy to use zoom features for zooming in on important areas of your maps.
- Works in US or Metric measurements.
- Works with any GPS receiver capable of outputting NMEA0183.
- Includes a "Data" tab that can be used for displaying information being output by your GPS receiver for diagnostics.
- Displays distances of mapped paths, useful for determining lengths of field tiling.

## Farm Works Mate X2 Reference Guide

- Displays sizes of mapped areas such as field boundaries and weed areas.

### **Scouting and Sampling Module**

- Allows you to create soil sampling grids to any size, pattern, and orientation. Site Mate can automatically assign sample IDs to each point.
- Allows you to display text with areas, lines, and points.
- Lets you enter an unlimited number of attributes such as scouting notes for mapped areas and points.
- Includes navigation tools for navigating to gridded points or any known point in a field.
- Includes features for creating and displaying legends for areas, lines, and points.

### **Variable Rate Control Module**

- Works with commonly used variable rate controllers.
- Creates “as applied” maps when working with most controllers.
- Gives you the ability to create a legend based on application rate.
- Displays total expected amount of product to be applied.
- Allows you to enter your swath width in order to see an application coverage map on the go.

### ***Guide Mate Overview***

Guide Mate provides guidance control and display for swathing applications. Guide Mate receives position, speed over ground (SOG), and course over ground (COG) from a DGPS receiver. Guide Mate then compares the COG and position to the desired swath pattern and produces a guidance display.

- Advanced navigation with “driver friendly” on screen steering graphics, acreage calculations, and numerous driving patterns (straight A-B, multiple contour modes, multiple headland modes, spiral, etc).
- Moving map display shows application accuracy while in the field.
- Acreage calculator during guidance mode.
- Pan and zoom features show close up view to detect gaps and over spray conditions.

- Can be used in conjunction with a Raven lightbar to control the lightbar.
- MicroGuide can be added for additional guidance support
- Will control Smartrax and Quicktrax autosteer systems.

## Using a Windows™ CE Device

If using the Farm Mate programs with a Windows™ CE device, you will need to configure your CE device and desktop computer to work together. The appropriate software must be installed and a partnership between the CE device and the desktop must be created. If installing to a laptop/desktop platform, skip to the Installation section of this manual.



**Note:** There are frequent model changes for CE devices. Though every attempt has been made to have these instructions as comprehensive as possible, it may be necessary to reference the CE device user manual for some instructions.

### ***Creating a partnership between the CE device and the desktop computer / laptop***



Creating a partnership allows the desktop computer and the CE device to communicate back and forth to each other. This communication is how the two computers will exchange information and how software will be installed onto the CE device. A new partnership must be created before the CE device may be used with a desktop computer. The basic steps for creating a partnership are as follows:

1. Connect the cradle (also known as a docking station) or cable of your CE device to your desktop computer or laptop. This will normally plug into a serial or USB port on your computer. An adapter may be required.
2. Install Microsoft Windows™ CE Services (ActiveSync) from the Microsoft Windows™ CE CD-ROM. This CD should be packaged with your CE device. This program will run a setup wizard that will step you through installing the necessary applications. You may also need your original Windows installation CD. You can also find the software by searching the web for Microsoft ActiveSync. You must, however, be careful of the software version you download.
3. After Windows™ CE Services (ActiveSync) has been installed, you may be prompted to restart your desktop computer. After restarting, place your CE device

## Farm Works Mate X2 Reference Guide

into the cradle. The **New Partnership Wizard** should now appear. Enter additional information such as a Device Name for your CE device. The device name is how your CE device will be identified in Windows™. After entering this information, the partnership will be complete.

Each time you put your CE device into the cradle or connect the cable, a message window will be displayed that indicates that Windows™ is connecting to the CE device. This process is critical, as it is what allows communication between the desktop/laptop and the CE device.



### ***Re-setting the CE Device***

If at anytime the software “locks-up” and the CE device will not respond to any of the buttons, use the stylus and press the soft reset button. It is not a bad practice to do this once a day.



## Getting Started

### *Installing the Farm Works Mate Programs*

The mate programs will be installed using the CD-ROM in your desktop or laptop machine regardless of whether the program will be run from the desktop, laptop, or CE device. If the mate programs will be run from a CE device, the CE device must be synchronized with the desktop machine throughout the installation process.

There are two important notes before you start installing your software:

- The files on all Farm Works installation CDs are compressed, so you cannot install Farm Works by copying the files.
- Choosing **Cancel** during installation halts the process and Farm Works will not be properly installed on your computer.

### Installation Procedures

1. Insert the Farm Works CD into the appropriate CD-ROM drive. Windows™ will automatically begin the installation process for you. If the installer does not start itself, choose **Run** from the **Start** menu and then type **D:\Setup** in the box under the command line. (substitute “D” for the letter of your CD drive) Select **OK**.
2. Select **Install Farm Works Mate Programs** from the installation screen and then select the programs that you wish to install. Most programs will require a cd-key or code in order to be installed. Code numbers will default to those previously entered if the selected programs have been installed in the past, but can be changed if necessary. These codes are packaged with each program that is sold.



3. Follow the instructions on the screen to complete the installation process.
4. After the program has been installed, a message will appear alerting you that the software has been successfully installed. You can now **Exit** the installation window.
5. If installing to a desktop or laptop, you may want to reboot the computer and if installing to a CE device, you will want to perform a soft reset.

## ***Registering Your Software***

To protect your copy of the mate programs and to receive information on future updates to the program, you must register it under the owner's name with a registration number provided by Farm Works. Registration takes just a few moments to complete and there are two options available for receiving registration numbers.

1. On-line registration
  1. Go to [www.farmworks.com/register](http://www.farmworks.com/register)
  2. Select the programs you have installed.
  3. Enter the Machine ID that is displayed on your screen, along with your cd key numbers and select **Submit**.
  4. Fill in your contact information, the place of purchase, and select **Submit Registration**. If you have completed the information correctly, you will receive an e-mail containing your registration numbers within an hour.
2. Call Farm Works Software

## Farm Works Mate X2 Reference Guide

1. Call 1-800-225-2848 Monday – Thursday 8AM – 8PM EST  
Friday 8AM – 6 PM EST  
Saturday 8AM – Noon EST
2. Make sure to have the Machine ID number ready or have the registration window brought up before calling.

**Note:** If the registration window does not appear upon opening the Mate programs, it may be located by going to **File > About Farm Site Mate... > Registration Info** within the Mate program.

When you receive the registration number(s), enter them into the correct registration boxes and choose **OK**. Be sure to write the Machine ID as well as the registration somewhere, such as on the inside front cover of your software manual, so that you will always have it. As long as the Machine ID number stays the same, the registration number will work for future installs.

## Synchronizing Data



Once the Mate programs have been installed and registered, the information that has been entered into the desktop software (Farm Trac+ or Site Pro) must be added to Trac Mate. When using Site Mate, the information collected can be brought into your desktop project through the synchronization process as well. During the synchronization process, Site Mate log files (.fgp) are synchronized directly from Farm Site Mate to a new layer within your main project. (Farm Site must be installed to synchronize with Site Mate)

### ***Synchronizing between Trac Mate and Farm Trac+ (or Site Pro)***

The process of exchanging data between Farm Trac Mate on the CE device or laptop (mobile unit) and Farm Trac+ on the desktop is called “synchronizing”. This process updates your permanent crop records in Farm Trac+ with those entered in the field, as well as the mobile unit with any new items added to the list of fields, equipment, or supplies. Any planned jobs that have been created in Farm Trac+ are also updated. Farm Trac Mate adds the option of synchronizing more than one project. To synchronize more than one project, you will have to complete the synchronization process while within each individual project.

In Site Pro, Trac Mate allows the synchronization of more than one client’s information. All clients will be synchronized when the process is completed.

### **Synchronization Process**

During the synchronization process, differences between the lists kept on the Trac Mate program and the desktop are reconciled. (Equipment, Supplies, Fields, etc.) This makes it possible to add items in the field and on the desktop without worrying that the items will

## Farm Works Mate X2 Reference Guide

be duplicated when the two machines are synchronized. When the synchronization process begins, you will be given the opportunity to match, or **Link**, new items from the Trac Mate program with those already on the desktop. You can also choose to create a new item on the desktop software. This means that it is possible to be adding new supplies in the field with Trac Mate while someone else is using Farm Fund\$ to record purchases of the same supplies.

Before records can be synchronized, each farming action should be marked as finished in Trac Mate. Unfinished jobs cannot be synchronized with Farm Trac+ or Site Pro.

### To begin synchronization:

1. Make sure Farm Trac Mate is closed on the mobile device.
2. If using a CE device, make sure it is connected and synchronized with the main computer using ActiveSync. If using a Titan RT, insert the usb drive into your computer's usb slot.
3. Select **Synchronize Trac Mate** from the **File** menu on your desktop computer. There will be several options available within this window.

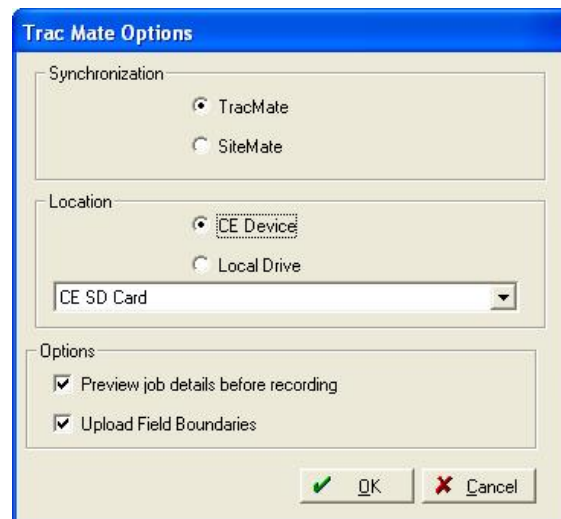

- a. **Synchronization:** Select whether you will be synchronizing Trac Mate or Site Mate. Note: If using Site Mate while performing a Trac Mate job, select Trac Mate.
- b. **Location:** Refers to the location of installation for the Trac Mate program. Select the appropriate location from the drop down list. If using a usb drive, select the appropriate Local Drive.
- c. **Options:**

## Farm Works Mate X2 Reference Guide

- i. **Preview job details before recording:** Select this option if you want to be able to view or edit the operation before the synchronization process is complete. If selected, the **Farming Box** will be displayed, allowing you to view or edit the farming operation.

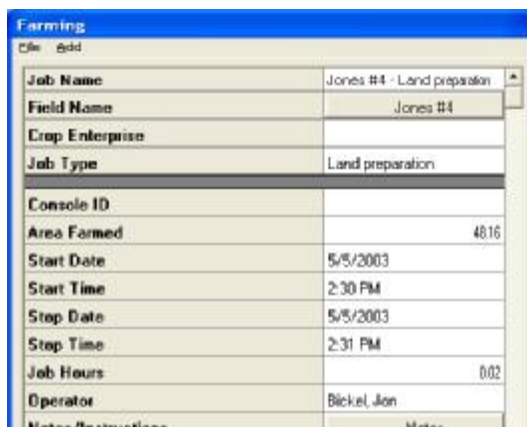

Farming	
Job Name	Jones #4 - Land preparation
Field Name	Jones #4
Crop Enterprise	
Job Type	Land preparation
Console ID	
Area Farmed	48.16
Start Date	5/5/2003
Start Time	2:30 PM
Stop Date	5/5/2003
Stop Time	2:31 PM
Job Hours	0.02
Operator	Bickel, Jon
Notes/Instructions	Notes

- ii. **Upload Field Boundaries:** Checking this box allows you to view field boundaries while working in Trac Mate when it is used in conjunction with Site Mate.

4. The Trac Mate Synchronization screen will show the progress of the sync process.



5. After the synchronization process is finished, you will get a message that the synchronization is complete.

### Linking New Information

The synchronization process allows information that has been added to the mobile unit, while in the field, to be linked to existing items on the desktop.

### To Link Information:

## Farm Works Mate X2 Reference Guide

1. Complete synchronization steps #1-3 as previously discussed. If new items have been added to Trac Mate, the **Linker** window will appear.

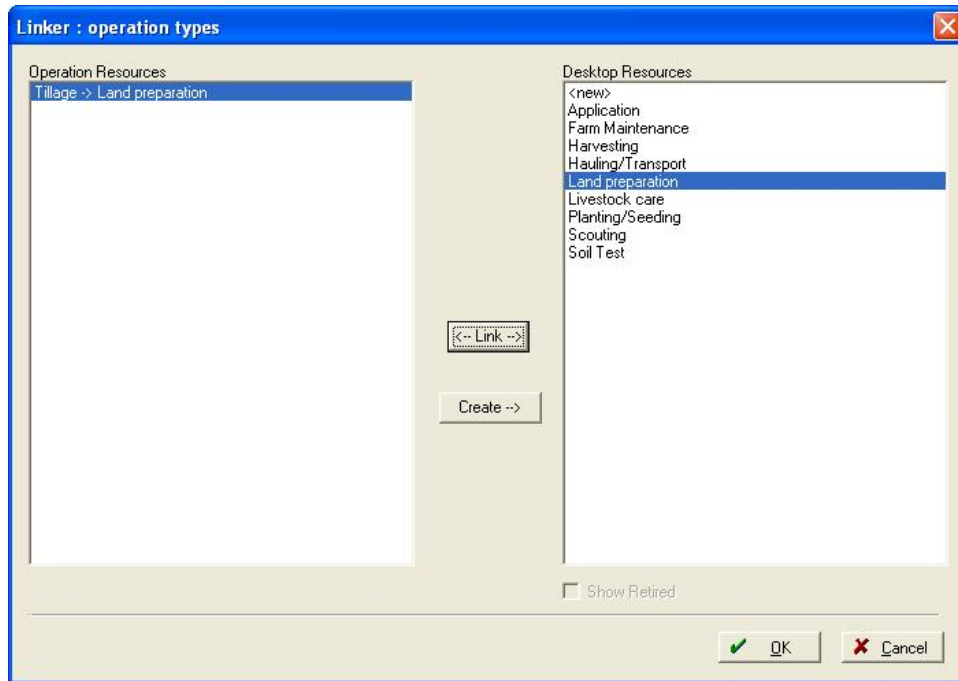

2. Highlight the new item on the left. This will be the item that was added within Trac Mate.
3. If the resource selected is a new resource, currently not on the desktop software, select the **Create** button. If the resource matches an item already on the desktop, highlight the item on the right side of the window and press the **Link** button.
4. Select **OK** and complete the link process for each item that was added to Trac Mate.

If new people or equipment were created, you will be prompted to enter the properties for each new item.

The properties of new supplies will also be entered during the synchronization process. If using Farm Fund\$, an account will have to be assigned to new supplies.

Once the synchronization process is complete, the new people, equipment, and supplies will be available on the **Inputs** tab. New fields will also be added to the **Farm** tab.

When data is synchronized, several things occur:

- All field records (Jobs and Regions) that were made as **Finished** with Trac Mate, will be loaded into Farm Trac+ or Site Pro. This will result in the updating of notations, crop histories, chemical records, and enterprise

## Farm Works Mate X2 Reference Guide

statements. The field colors and patterns on your map (if using Farm Site) will also reflect the farming actions that have been recorded with Trac Mate.

- Any items such as fields, equipment, people, supplies, and crops that have been added to the desktop program since the last time that you synchronized will be added to the lists in Trac Mate. This process ensures that your Trac Mate program is always using an up-to-date list of items for your farm.
- All of the field records that were marked as **Finished** will be removed from Trac Mate. Jobs marked as **Incomplete** will be left in Trac Mate to be finished later.

If using Farm Site as well:

- An updated map that includes all field boundaries will be uploaded to Trac Mate **IF** the Upload Field Boundaries box is checked.
- Job logs (GPS maps) that were created in Trac Mate/Site Mate will be imported into Farm Site or Site Pro and placed on new layers.

The process of synchronizing can be done as often as you like, however, remember that there are limits to the amount of data that a CE device can hold. There are also risks to storing too much data on the CE device. The data on the main memory of the CE unit will be lost if the unit loses battery power or is destroyed. It is recommended to synchronize the data at least once a week, or even daily.

### ***Synchronizing between Site Mate and Farm Site (or Site Pro)***

Once you have created files using Farm Site Mate, that information may be brought into your desktop project through the synchronization process. During the synchronization process, Site Mate log files (.fgp) are synchronized directly from Farm Site Mate to a new layer within your desktop project.

#### **To synchronize Site Mate log files:**

1. Make sure Site Mate is closed on the mobile unit.
2. If using a CE device, make sure it is connected to your computer and synchronized using ActiveSync. If using a Titan RT, make sure you have the usb drive with the files on it inserted into your desktop computer.
3. Select **Synchronize Trac Mate** from the **File** menu within your desktop program. Several options will be available.

## Farm Works Mate X2 Reference Guide

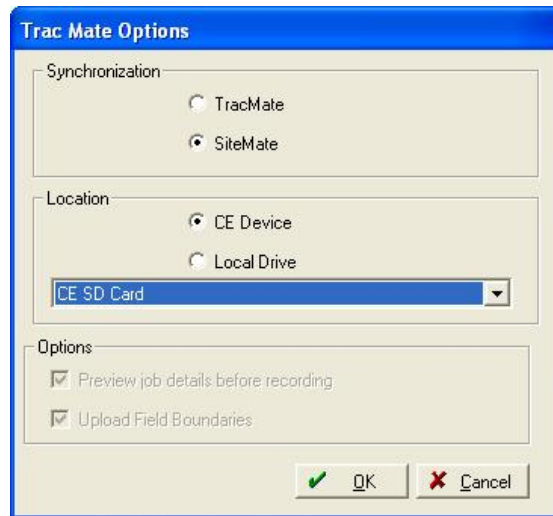

- a. **Synchronization:** Select whether you will be synchronizing Trac Mate or Site Mate. Note: If using Site Mate while performing a Trac Mate job, select Trac Mate.
- b. **Location:** Refers to the location of installation for the Site Mate program. Select the appropriate location from the drop down list. If using a usb drive, select the appropriate Local Drive.

**Note:** Site Mate files must be saved in the My Documents or TMSM Data/Scouting folders to allow the files to be synchronized.

4. Select **OK** to begin the synchronization process.
5. The **GPS Logs** window will appear. This window will display all Site Mate log files that have been saved in the My Documents or TMSM Data/Scouting folders.
6. Highlight the file(s) to be synchronized. Multiple files may be synchronized at the same time by holding down the <Ctrl> or <Shift> key while selecting the desired files.
7. Check all appropriate boxes under the **Options** area.

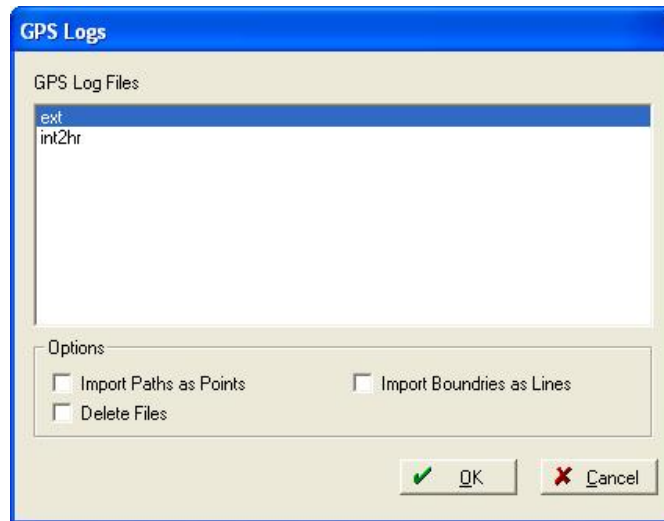

- a. **Import Paths as Points:** Allows Site Mate path files to be imported into the desktop project as points. The points will keep the attributes added to the path file within Site Mate.
  - b. **Import Boundaries as Lines:** Allows Site Mate boundary files to be imported as lines. No attributes will be tied to the new 'Lines Only' layer.
  - c. **Delete Files:** Select this option if you would like the Site Mate files to be deleted from the selected synchronization location after importing.
8. Select **OK** to import the selected file(s). The files will be imported to your desktop as a new layer.

## Saving Information and Preventing Data Loss

Information is saved as it is entered and is kept on the mobile device even after the unit is turned off. However, if the main batteries go dead and the backup battery is dead, all data in all programs on the unit will be lost. (The Titan RT is not susceptible to this) Some units also have a "hard reset" option that will remove all programs and data from RAM. Refer to your unit's documentation for details on proper care and maintenance.

If your Windows<sup>TM</sup> CE Device has the capability of using a removable storage card (Compact Flash or Secure Digital cards), you can protect your data by saving it to the storage card. You can also choose to synchronize Trac Mate data directly to a card by choosing "CE Card" for the Synchronization Location. Installing the program to a storage card is also an option when initially installing the software. If the battery goes dead, the program will re-install itself onto the CE device if it was installed on the storage card. There is an option in the Mate programs to **Save Settings to Card**. This will save all registration information as well as all settings within the program to the storage card. If the battery goes dead, you simply have to select **Load Settings from Card**.

## ***Viewing Data after Synchronization***

### **Trac Mate**

Once the operations have been synchronized, there are several ways that the data that was entered in Farm Trac Mate can be viewed in Farm Trac+ or Site Pro. Each job will show up under the **Job** tab as a separate entry.

1. Notations will be recorded for each job. Notation reports can be viewed under **Field** in the Reports menu. You can also right click on a field in the **Map** tab (Farm Site only) and select **Notes** or **Reports**.
2. You can view/edit the job information by highlighting it in the **Jobs** tab and selecting **Properties**.
3. A report may be printed that includes a map (if Site Mate and Farm Site are used) by highlighting the job in the **Jobs** tab and selecting **Print**.
4. If Site Mate was used with Trac Mate, you can locate the job in the tree and double click on it to view the job map on the map tab.

### **Site Mate**

The synchronization process automatically creates a new layer for each log file that is synchronized to the main program. New log files, or Trac Mate jobs that include log files, are synchronized to Farm Trac+ or Site Pro. They will

1. If only using Site Mate, the new layer will not be associated with any Client, Farm, or Field. You can assign it and also place it in a category by right clicking on the layer in the **Farm** box and selecting **Properties**.

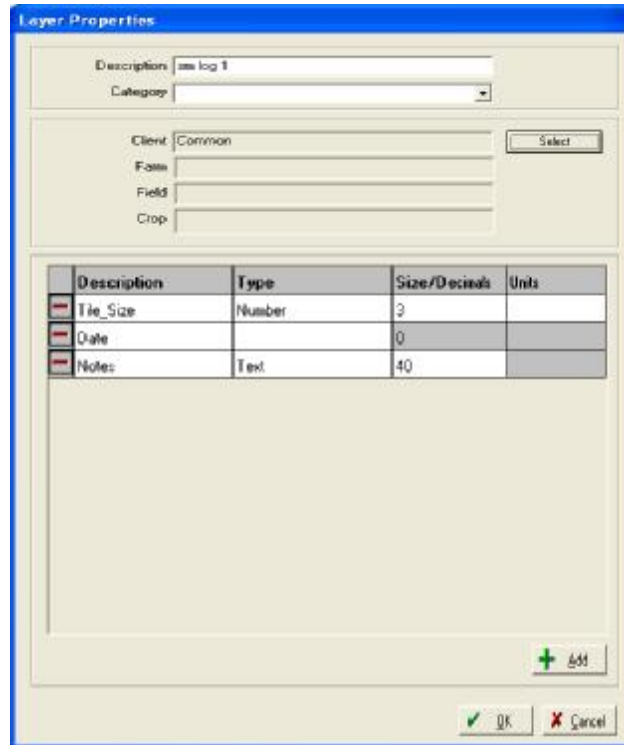

- a. You can choose a category, if appropriate, and then press the **Select** button to assign the layer to a Client, Farm, Field, and Crop.
- b. The layer will then show in the tree layout in the selected location.

For more information on re-organizing layers and data, refer to the Farm Site manual.

## Configuring the Mate Programs

Before beginning to use Trac/Site Mate, you will want to configure the program to function as you desire. These configuration options are available on the **Config** tab. There are four main sections of this tab. **Settings**, **Logging**, **Display**, and **Advanced**. If Trac Mate is installed, there will be a Trac Mate option and with Guide Mate installed, a Guide Mate option will show as well.

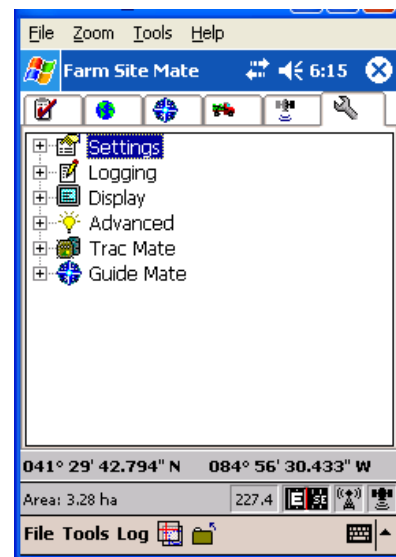

## Settings

The **Settings** section of the **Config** tab is where basic information is configured.

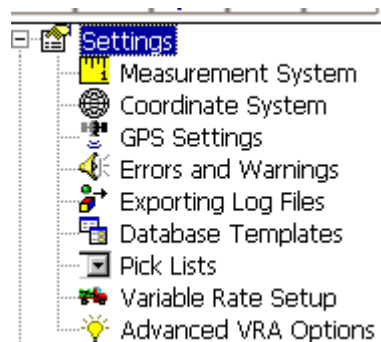

### Measurement System

The **Measurement System** allows users to select the units of measure to be used in Site Mate. Users will be able to display measurements in US-English or Metric as well as specify if the measurements are for agriculture or turf related operations. You can also choose to display distances over a certain length as miles (km) instead of feet (meters).

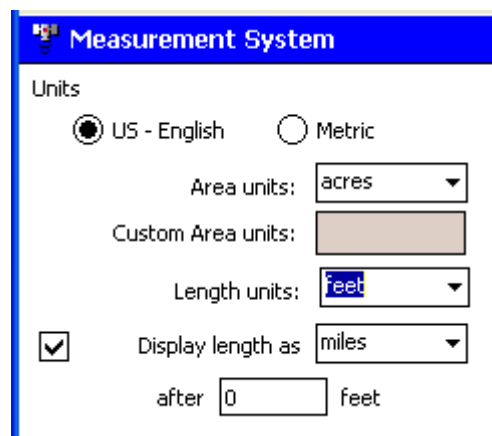

### Coordinate System

The Coordinate System setting allows users to select the coordinate system to be used for displaying geographic coordinates in Site Mate. The coordinate system does not have to match the coordinate system of the GPS receiver. The coordinate system that is selected here is for display purposes only. Site Mate will always log data in the Lat/Long system.

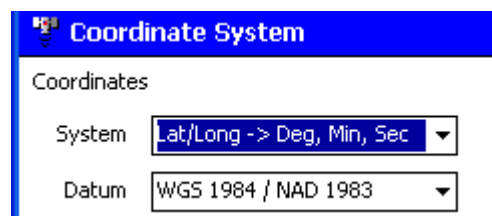

### GPS Settings

The GPS Settings screen displays several tabs: **Source**, **Comm**, **Quality**, **Offset**, **Simulation**, and **Output**.

The **Source** tab is where the GPS source will be selected.

- *GPS Receiver on COM Port* – This option is used when you wish to create a map based on data received from the GPS receiver. When this option is selected, you will use the **Comm** tab to enter the settings for your GPS receiver.

## Farm Works Mate X2 Reference Guide

- *GPS Simulation* – This option allows you to simulate the mapping of a boundary or swathing without having a GPS receiver attached. This lets you experiment with the program to become familiar with it without having to connect a GPS receiver and be outside. When this option is selected, you can use the **Simulation** tab to enter settings for the simulation.
- *Manual Location Entry* – This option is used to manually record positions on your map without a GPS receiver. If, on the map tab, the Manual Coords Tool is selected, you can click anywhere on the map and that is where the location will be.

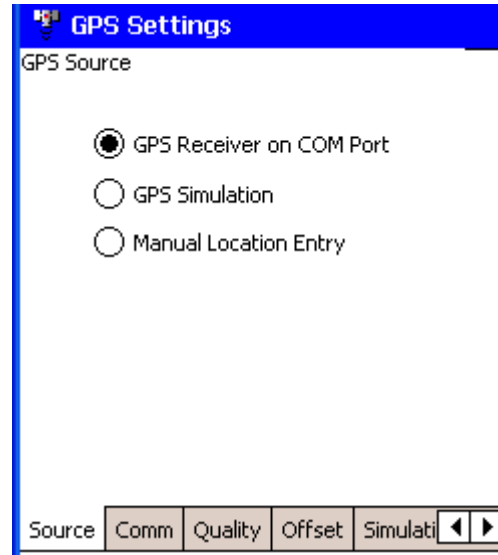

The **Comm** tab allows you to configure Site Mate to communicate with your external GPS receiver. Port, Baud Rate, Data Bits, Parity, and Stop Bits will have to be set to match your GPS receiver. The bottom port on most handheld devices is Comm 1. If you do not know your port settings, you can select **Auto Baud** and Site Mate will search and find a GPS receiver that is connected and outputting.

Note: Site Mate needs, at a minimum, the NMEA strings GGA and VTG.

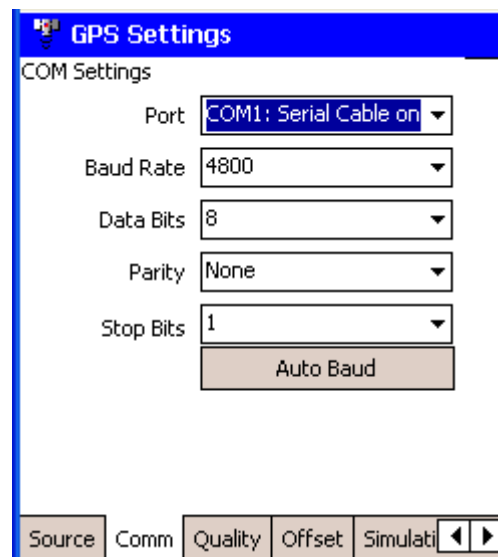

The **Quality** tab allows you to select a minimum GPS quality that Site Mate will use to log data. If the quality falls below this setting, Site Mate will no longer log data.

- *Minimum GPS Quality* allows you to control if differential is required and what level.
- *Maximum HDOP* is another quality indicator that is tied directly to the number of satellites being used. Some guidance products, for example, will not guide you over a 2.0 HDOP.
- *Honor NMEA Checksum* simply validates the messages coming through to the GPS receiver.

Note: If you have a GPS position, but the Site Mate will not log, try relaxing some of the quality filters.

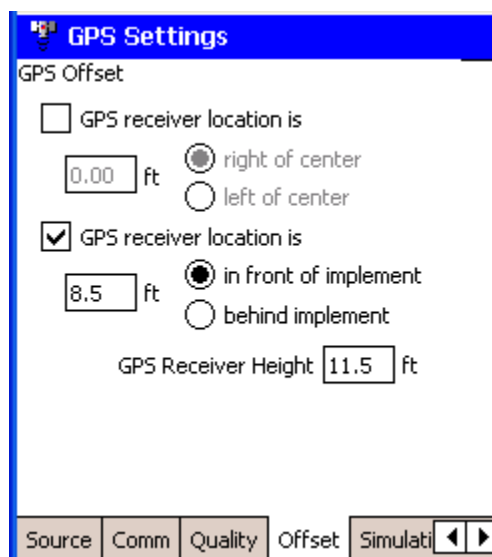
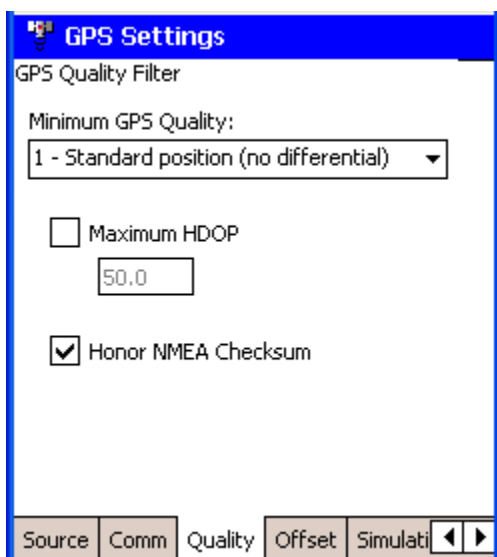

The **Offset** tab allows you to compensate for an antenna position that is not centered with the vehicle as well as enter antenna height and how far it is from the implement so the logging with display correctly on the map.

The **Simulation** tab is used only when the GPS source is selected as GPS Simulation.

- *Pattern* – Choose the pattern that you want to simulate: either Boundary, Swathing North-South, or Swathing East-West.
- *Speed* – Choose the speed at which the simulated position will move across the screen.
- *Swath* – Choose the swath width of the path that you want to simulate.
- *Clear Log After Each Pass* – Select this option to clear the simulated log after each pass so the paths do not overlap.

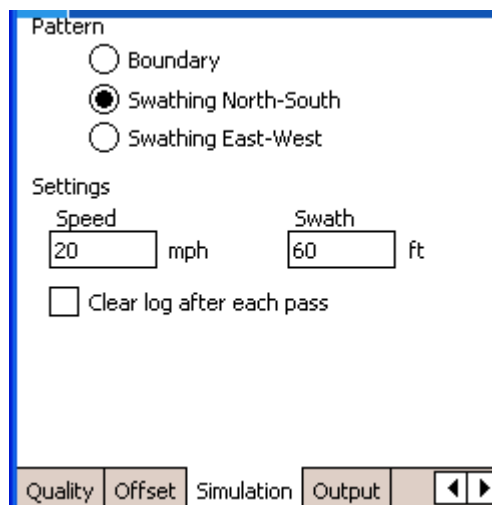

The **Output** tab is used to send the NMEA data strings out to a communications port. Check the box next to Output NMEA to Comm Port and select the correct Port, Baud Rate, Data Bits, Parity, and Stop Bits.

Note: This option is rarely used, but can be helpful when testing light bars or other devices when no GPS receiver is available. It can also be used to “pass on” GPS data being received. This box should be unchecked if output is not needed, as it can tie up a Comm port on a handheld device.

You can also choose to Log raw GPS output to text file if needed.

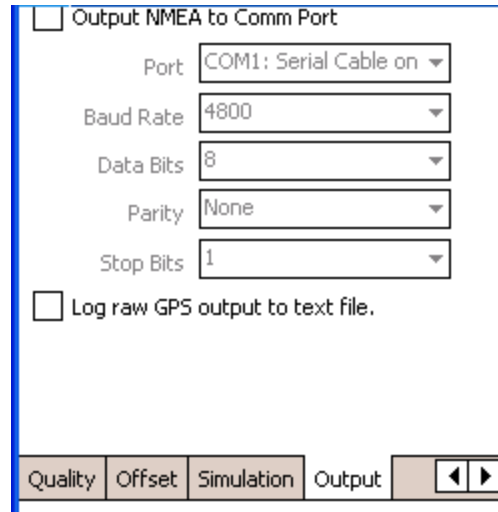

## **Errors and Warnings**

These options allow the user to select the type of notifications used during the logging process.

- *Flash Message Line* – Site Mate will flash a message line at the bottom of the screen when GPS data is not received.
- *Audible Message Beeps* – Site Mate will beep when GPS data is not being received.
- *Beep When Logging* – Site Mate will beep as information is being logged.
- *Confirm before closing a boundary* – If automatic closing of boundaries is selected, this will confirm that the user wants to close the boundary before automatically doing so.

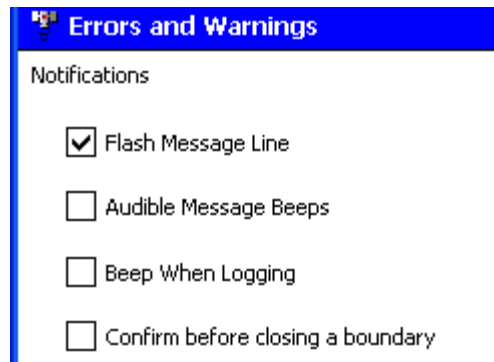

## **Exporting Log Files**

These options tell Site Mate how to handle the exporting of the log files when they are complete.

- ALWAYS export the log file will export the log file each time the log file is saved or closed.
- NEVER export the log file will never export the log when it is saved or closed.

- ASK each time a log is saved will prompt the user each time a log is saved or closed asking whether or not to export the file.

Notes: If ALWAYS is selected, you will need to select a **Default Export Type**. Arcview Shape File (shp), Mapinfo Interchange File (mif), or Farm Works GPL File (gpl)

With the version X2 of Farm Works desktop program, there is hardly ever a need to export the log file, as it can easily be synchronized instead.

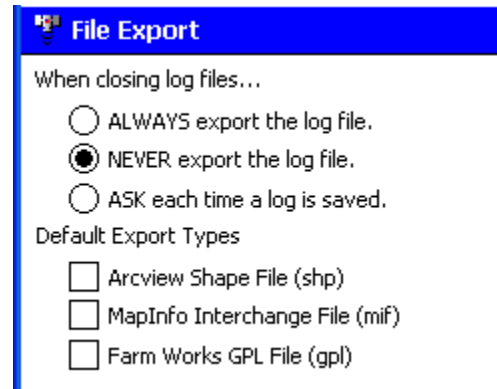

## **Database Templates**

This option is only available with Site Mate Scouting or VRA.

Each time that you log data, you may create a database template that is linked to the log file. This means that in addition to mapping paths, points, and boundaries, you are able to add attribute data. Templates may be created before opening a new log file or during the process of creating a new log file.

Note: If using pick lists, you will need to set them up previous to creating a database template.

To create a new template:

1. From the **Configure** tab, open the **Settings** area and select **Database Templates**.
2. A list of previously created templates will be displayed. These templates may be edited or deleted, if desired. Select **New** to create a new template.

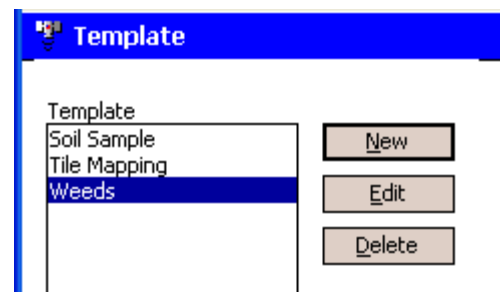

3. When creating a new template, enter a template name. This name should describe how the template is to be used. Examples would include: “Weeds” for mapping weed areas or “Fields” for mapping field boundaries.
4. The **Attributes** area will display a list of the items that will be recorded in the database.

## Farm Works Mate X2 Reference Guide

5. Select **Add** to add a new item to the list, then enter a **Description**. The descriptions pertain to individual attributes included in the database. Examples for a weed layer could be *Type*, *Intensity*, and *Notes*.

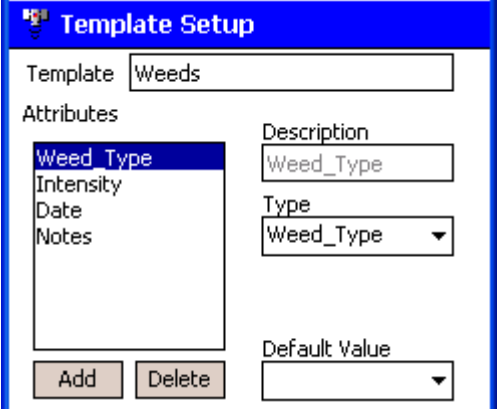

The screenshot shows a 'Template Setup' window. At the top, the title is 'Template Setup'. Below the title, there is a 'Template' text box containing the word 'Weeds'. Underneath, there is an 'Attributes' section with a list box containing 'Weed\_Type', 'Intensity', 'Date', and 'Notes'. To the right of this list, there are three input fields: 'Description' with the text 'Weed\_Type', 'Type' with a dropdown menu showing 'Weed\_Type', and 'Default Value' with a dropdown menu. At the bottom left of the window, there are two buttons labeled 'Add' and 'Delete'.

6. Select a data **Type** for each data item being recorded.
  - a. Data types include Number, Text, Date (automatically enters the date), and Sample ID (automatically assigns an ID to each sample logged). Additionally, any previously created pick lists will show up as options for Type. In the weed example: Type of weed would have a data type selected as the name of the pick list created for the different types of weeds, Intensity could be either Text or Number, and Notes would be Text.
  - b. Selecting a Text data type provides an option to select the quantity of characters. This value defaults to 40, but can be edited.

Note: If selecting pick list as the data type, the attribute name will be changed to the name of the pick list.

7. If a **Default Value** is entered, the program will use this value each time that a point or boundary is logged. This value can be changed when necessary. This should be used if most of the data being logged will have the same value.
8. Select **Add** to create additional attributes to the template. The template may include as many different items as you like. You will need to create an attribute for each piece of information that you would like to record. For example, if you need to identify more than one weed variety within a defined area, an attribute will need to be created for each identified weed type.
9. Select **OK** when finished.

Database Templates may be edited or deleted at any time as long as a job is not in progress.

To edit a template, highlight the desired template from the list and make the necessary changes.

To delete a template, highlight the unwanted template and select **Delete**.

## **Pick Lists**

This option is only available with Site Mate Scouting or VRA.

To make the process of entering data into Site Mate easier, you can create Pick Lists. Pick Lists give the ability to create lists of items that can be selected for mapped areas and points. For example, if you will be mapping weed problem areas, a choice list can be created that includes each type of weed that you will be scouting. Then, when a weed area is mapped, the appropriate weed can simply be selected from a list.

To set up Pick Lists:

1. Select **Pick Lists** underneath **Settings** on the **Config** tab.
2. A list of previously created pick lists will be displayed. These pick lists may be edited or deleted as desired. Select **New** to create a new choice field.
3. When creating a new pick list, you will first enter a pick list name. This description should describe the type of data the choice field will be used for. An example would be “Weeds” where the choices will be the different types of weeds that you will be scouting.
4. Select **New** to add a new value to the list. Enter the new value and select **OK**.

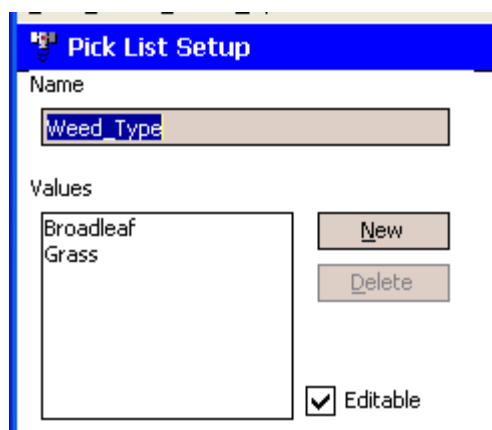
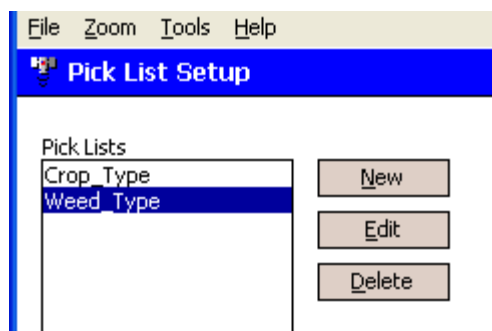

Note: The new values that you set up here will be the actual names that will be selected when scouting. For a “Weeds” choice list, the names of all of the weeds that you will be scouting will be added to the list.

5. Repeat the previous step for each value that will be added to the pick list.
6. Check the **Editable** box if you want to be able to add items to the pick list while logging in the field. This is helpful as many times you will not know every item that you will be logging.
7. Select **OK** when all values have been added to the pick list.

You may **Edit** or **Delete** a pick list from this area as well.

## Variable Rate Setup

This option allows users to setup controllers that will be used to complete a VRA job. Users will be able to **Edit** an existing VRT Setup, **Add** a new one, or **Delete** an unneeded setup. This will only be available with Site Mate VRA.

To create a new VRT Setup:

1. Select **Variable Rate Setup** from the **Settings** section of the **Config** tab.
2. Select **New**. The VRA Controller screen will appear. Setup information for the controller will be entered on the tabs displayed – General, Map, Applicator (App), Controller (Ctrl), and Notes.
3. On the **General** tab, enter a Setup Description for the controller setup that you are creating. Choose the type of controller you are using from the drop down list and select the Comm Port to which the controller is connected.

Note: You will usually want a separate variable rate setup for each controller that you will be using. If one controller will be used with different products or machines and they require different settings, you may want to create a separate setup for each one.

4. On the **Map** tab, enter the Default Rate. This is the rate that will be sent to the controller if you go outside of the defined area on a variable rate prescription map. Set this to zero if you do not want it to turn on outside of the map.
5. Enter the conversion of map to controller units. There are times that the units on the prescription map do not match the units that the controller needs. If the map is in tons and the controller needs pounds, you would enter a conversion of 1 map unit = 2000 controller units. If both units are the same, simply enter 1 map unit = 1 controller unit.

## Farm Works Mate X2 Reference Guide

6. On the **Applicator** tab, enter the settings related to the rate controller and the GPS receiver

- a. Feed Delay – This is the time (in seconds) that it takes for the implement to respond to a change in rate.
- b. Following Distance – This is the distance (in feet or meters) from the GPS receiver to the distribution point of the implement. If the receiver is behind the boom section, for example, enter a negative number.

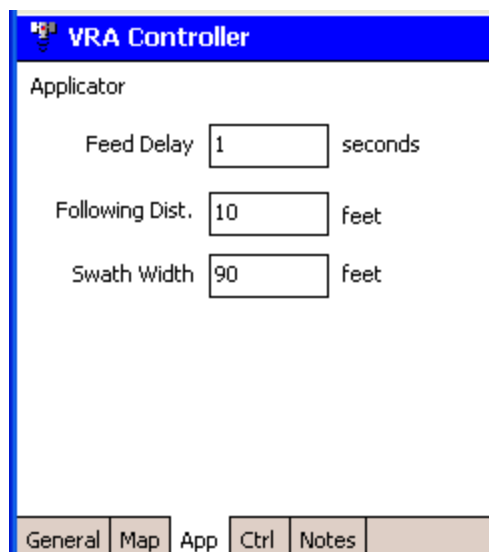

The screenshot shows the 'VRA Controller' window with the 'Applicator' tab selected. It contains three input fields: 'Feed Delay' with a value of 1 and the unit 'seconds', 'Following Dist.' with a value of 10 and the unit 'feet', and 'Swath Width' with a value of 90 and the unit 'feet'. At the bottom, there are tabs for 'General', 'Map', 'App', 'Ctrl', and 'Notes'.

Note: You will still need to enter GPS offsets in the GPS Settings screen. This value has no effect on those.

- c. Swath width – This is the width of the path that will be displayed on the screen as you work the field. If you enter this as the actual implement width for your equipment, you will see a coverage map displayed on the screen as you drive.
7. On the **Controller** tab, enter the information specific to your controller. See Appendix A for more information.
  8. The **Notes** tab can be used for any general notes related to this setup. You may want to include notes of settings that you need to make in the controller itself or specific cables that will be needed.
  9. Select **OK** to save the setup. It will now be added to the VRT Setup list.

You can also select the **Setup** button on the map tab once a VRA Job has been started to access these settings.

### **Advanced VRA Options**

This option is only available with Site Mate VRA. This allows a user to configure how Site Mate will respond to the variable rate controller.

1. The **General** tab allows the user to select whether or not they want the status of the booms to control the logging on Site Mate. If the “Only log data when boom or spreader switch is on” box is checked, the logging will stop when the booms are off.

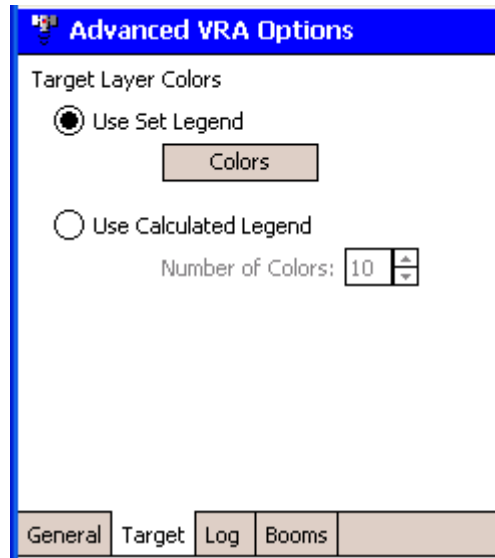
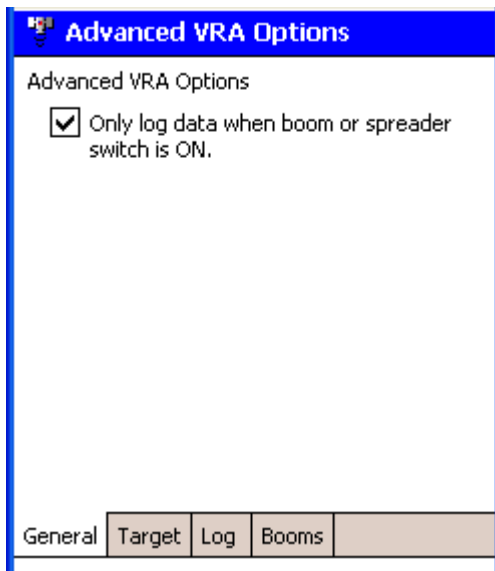

2. The **Target** tab allows you to select how you want the prescription map to be displayed. You can either use a **Set Legend** that you create, or let Site Mate use a calculated legend and you specify how many colors you want displayed.
3. The **Log** tab contains settings that will change how the coverage map will look. You can choose Rate Map (points) and set the legend yourself, Coverage Map (paths) which will display all one color, or Boom Sections (polygons) which will show when individual boom sections turn on and off.

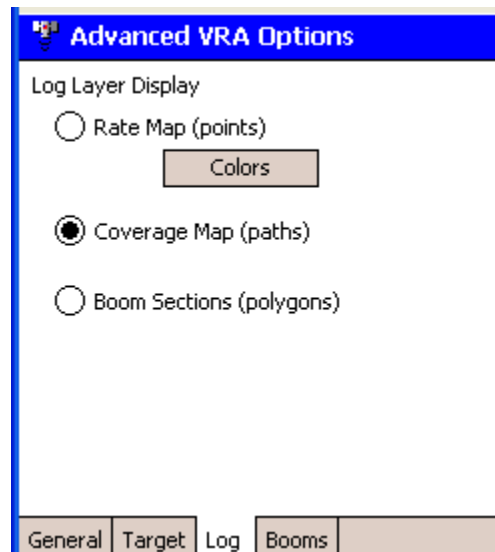

4. The **Booms** tab allows you to set up the configuration of your boom sections. Select the ordering under **Type** and how many boom sections there are.
  - a. Next to the boom number, enter the width of that boom in the units displayed.
  - b. Enter the distance from the center of the booms to the GPS receiver if there is an offset.
5. Press **OK** when finished with the Advanced VRA Setup.

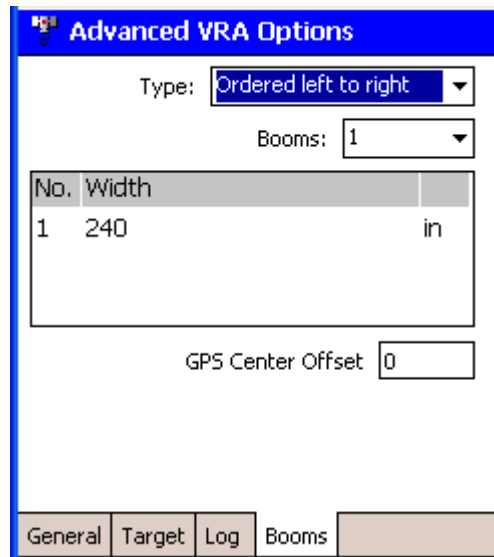

## Logging

### Auto Logging

These settings take effect when Automatic logging is selected. This means that the user does not have to press Log for a position to be recorded.

- *Recording Interval* – Refers to the interval in which data is logged in Site Mate. Users may enter a distance and/or a time interval. Whatever criteria is set must be met before Site Mate will log a position. If using a combination of time and distance, both criteria must be met before Site Mate will log any data.
- *Auto-close boundaries* – This option has Site Mate close the boundary and stop the logging when you get within the specified distance of your starting point of the boundary.

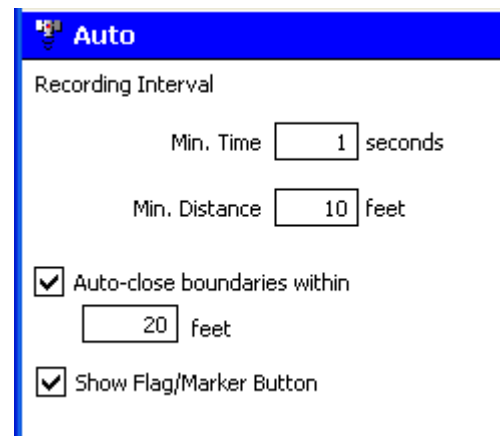

- *Show Flag/Marker Button* – This option will display the flag button on the map tab to easily flag objects in a field during a job.

### Sample IDs

- *Log Sample IDs* (Site Mate Basic only) – If this option is checked, Site Mate will assign Sample IDs to each logged point.

- *Check for Unique IDs* – Site Mate will verify that an ID will not be used twice in the same log file.

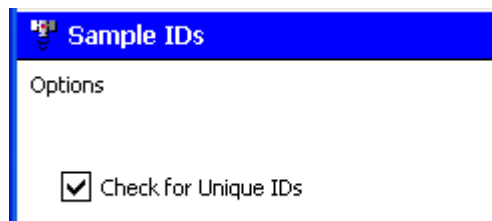

## Offset

Site Mate can apply an offset to any position being logged. This can be helpful if mapping a boundary and you cannot drive directly on top of the boundary. You simply enter which direction the object is that you want to map from the receiver and a distance and Site Mate will apply the offset. (if the boundary is left of the receiver, use a left offset)

Note: Be sure not to back up when logging an offset, as what would have been a right offset will be a left offset when going in reverse.

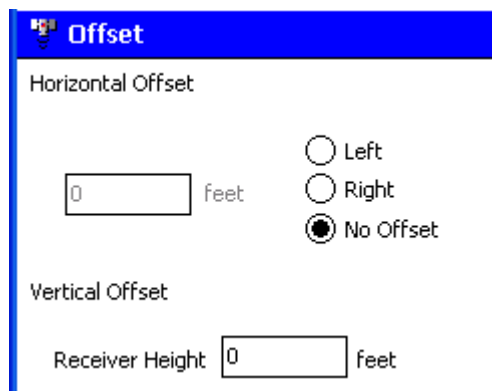

## *Display*

### Current Position

This option allows the user to configure how the current position is displayed. The shape can be selected, as well as the color and size of the icon. The size can be based on feet (meters) or pixels. If set to feet, the icon will get smaller as you zoom out, where if it is set to pixel, it will always appear the same size on the map screen.

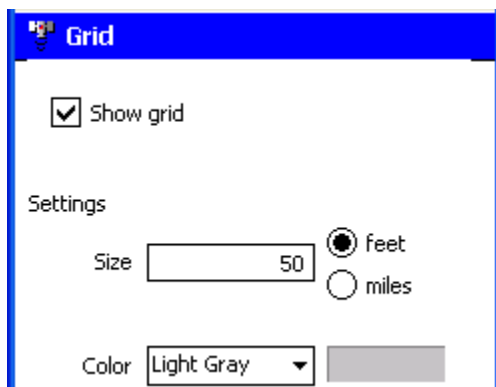
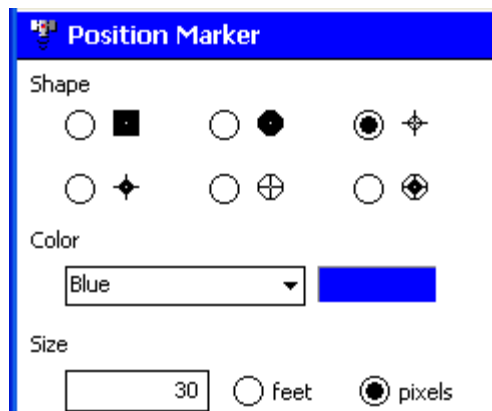

### Grid

The grid option will display grid lines on the map tab so the user has a reference as to distances. Under settings, choose the size as well as the color you would like the grid to be displayed as.

## **Indicators**

This option allows you to choose what, if any indicators are shown on the map screen.

- *Show Coordinates Line* – will display the current GPS coordinates at the bottom of the screen.
- *Show Speed and GPS Status Line* will display the ground speed as well as the status of the GPS at the bottom of the map screen.
  - *GPS and Differential Status* will display indicators showing whether or not you have GPS signal as well as Differential. When the indicators are black, you have signal.
  - *Number of Satellites and HDOP* displays how many satellites are being used as well as the HDOP value.

The screenshot shows the 'Indicators' settings menu. It has a blue header with the title 'Indicators'. Below the header, there are four options, each with a checkbox or radio button and a text label. The first two options are checked: 'Show Coordinates Line' and 'Show Speed and GPS Status Line'. The last two options are not checked: 'GPS and Differential Status' (which has a radio button) and 'Number of Satellites and HDOP' (which has a radio button).

## **Boundary**

Users will be able to select whether the actual and/or the offset boundary line will be mapped. A color for each can also be selected. Only the selected option will be displayed on the Map tab of Site Mate. The border width can also be entered here. If zero is entered, the line will change width automatically based on the zoom level. If offset is selected and there is no offset entered, the actual path will be displayed.

The screenshot shows the 'Boundary' settings menu. It has a blue header with the title 'Boundary'. Below the header, there are two sections: 'Display' and 'Border'. In the 'Display' section, there are two options: 'Actual' (unchecked) and 'Offset' (checked). Each option has a color selection dropdown and a corresponding color swatch. 'Actual' is set to 'Black' with a black swatch, and 'Offset' is set to 'Red' with a red swatch. In the 'Border' section, there is a 'Width' input field with the value '0' and the unit 'feet'.

## **Path**

The actual and/or the offset path line can be displayed as well. Once again, only the selected option will be displayed on the Map tab of Site Mate. The width of the line to be logged will also need to be entered. Entering a zero will cause the line to change widths based on the zoom level. If offset is selected and there is no offset entered, the actual path will be displayed.

The screenshot shows the 'Path' settings menu. It has a blue header with the title 'Path'. Below the header, there are two sections: 'Display' and 'Path'. In the 'Display' section, there are two options: 'Actual' (unchecked) and 'Offset' (checked). Each option has a color selection dropdown and a corresponding color swatch. Both 'Actual' and 'Offset' are set to 'Black' with black swatches. In the 'Path' section, there is a 'Width' input field with the value '28' and the unit 'feet'.

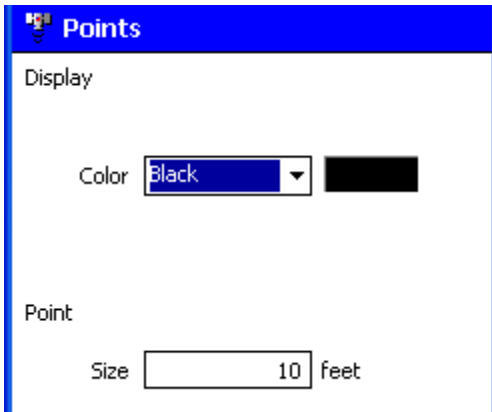

## Points

Enter a color and a size for the points that will be logged with Site Mate.

## Background

Select a color for each background file type, Boundaries, paths, and points. The line width will apply to polygons as well as lines. Entering a zero for the width will cause the line to adjust based on zoom level.

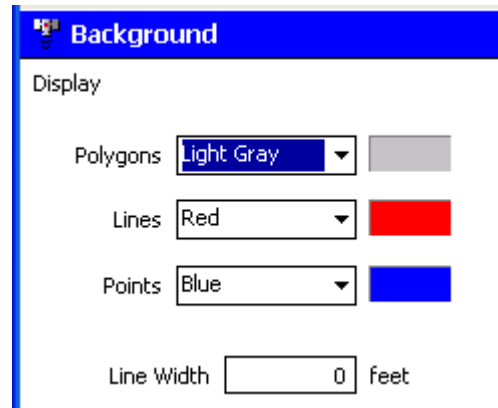

## Advanced

### Advanced Logging Options

- *Allow Suspended Logs* – When this option is selected, users will be able to suspend a log in progress and start a new log. This can be helpful when logging more than one type of information at the same time. For example, if you are logging a path and want to log a point, you can suspend the path and then map the point without completely stopping the path log.
- *Enter Attributes Before Logging* – When selected, users will be prompted to add attributes to a log file as soon as the log is created.
- *Default Attributes to Previous Log* – When selected, the attributes of a new log file will default to the same attributes that were used on the previous log. This is helpful when a lot of the information being logged will stay the same.
- *Enable Implement Switch* – If an implement switch is being used, it must be enabled here. (Do *not* check this box if an implement switch is not connected!)

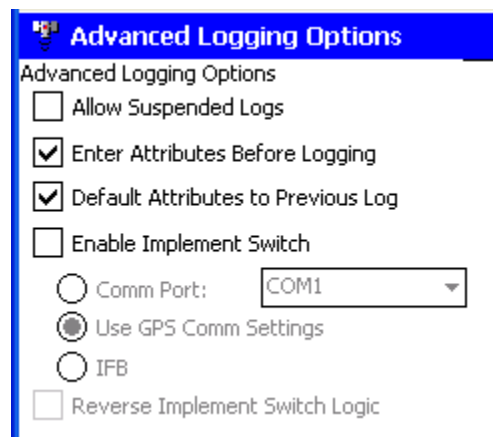

An implement switch can be used to turn the logging on and off automatically. Select how the implement switch is connected to Site Mate.

- Reverse Implement Switch Logic – If logging is backwards to what it should be (off when it should be on and vice versa), select this option to reverse the logic.

### Laser Range Finder

Site Mate allows you to connect a Laser Range Finder to your computer or CE device. A laser range finder is a device that uses a laser to log points in the field without actually positioning the GPS receiver at the point.

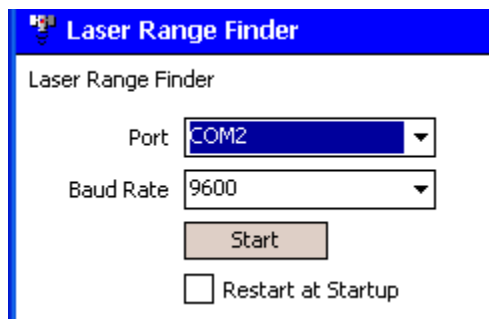

### Tilt Compensation

Farm Works offers a tilt compensation module that corrects the GPS position based on the tilt of the machine. The tilt compensation must be configured within Site Mate to function properly. The module must be connected to Site Mate to configure it.

- The receiver height will be set to match the antenna height entered in the GPS Settings previously. To set this, press **Reset GPS height in TCM**.
- You will then need to tell the terrain compensation module (TCM) where its level state is. Park the vehicle so it is level and press **Set tractor is level state**.
- When finished, choose **Save settings in TCM memory**.

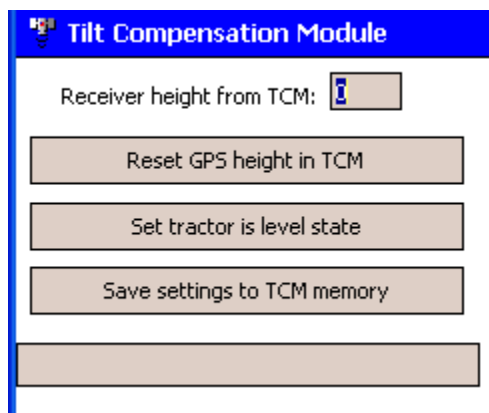

### **Trac Mate**

From the Trac Mate option on the **Config** tab, you can add, edit or delete the Trac Mate resources being used. Select each of the items to modify the lists: **People**, **Equipment**, **Supplies**, and **Other Lists**. You will then be able to create New, Edit, or Delete unwanted items.

### **Guide Mate**

### Indicator

- Select the **Zoom Level** by entering a **Look ahead** value. The larger the look ahead, the smaller the indicator will appear.
- **Indicator size** controls the size of the circle in the center of the indicator. If it is entered in feet, it will change size based on the zoom level. If it is entered in pixels, it will always appear the same size on the screen.
- **Indicator movement** controls whether the arrow rotates as you turn (Moving) or the screen rotates (Stationary).

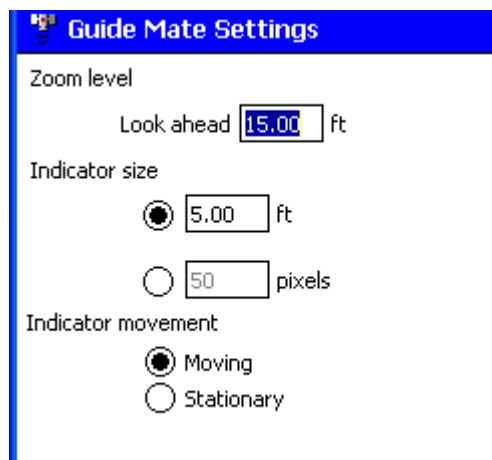

## Lightbar

- If using an **External lightbar**, you will select the appropriate settings here. You can choose which Comm port it is communicating on as well as the Brightness. Notice there is an easy way to switch from Day to Night mode to dim the lightbar.
- You can also choose to show or hide the **On-Screen lightbar**. This will display a lightbar on the guidance screen.
- If you press the **Settings** button, you can adjust the distance between lights, choose whether to follow the lights or drive away from them, and whether or not to display the lightbar on the Map tab.

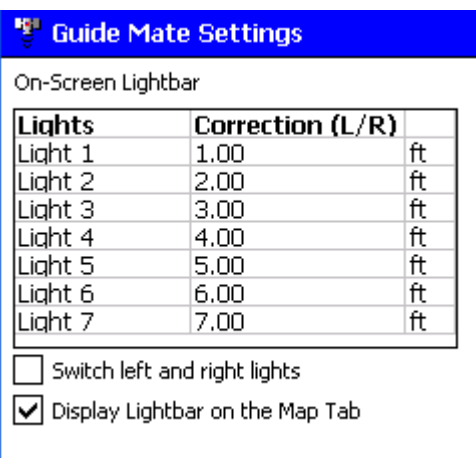
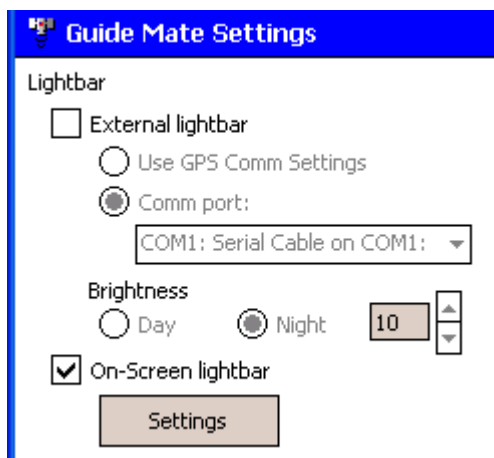

## Headlands

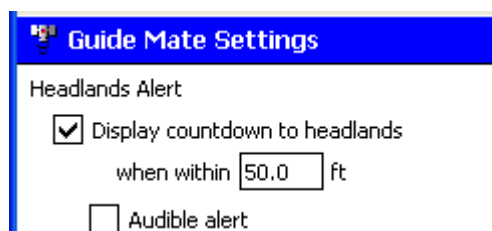

Guide Mate can display a warning when coming into the headlands. This feature only works when you use a headland pattern. Check the box to **Display countdown to headlands** and enter how far from the headlands you want the warning to display. You can also choose to have an **Audible alert** when coming into the headlands.

## Micro-Guide

Farm Works offers a Bluetooth enabled Micro-Guide Lightbar to assist with guidance. If using one, check the box to enable it, select the correct Comm Port for Bluetooth and select the correct baud rate.

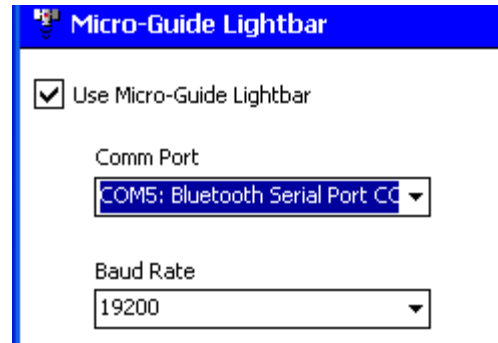

## Using Farm Trac Mate (without Site Mate)

Once Farm Trac Mate has been installed and registered, you may start entering field records. This chapter is designed to give you the basics on how to use Trac Mate for entering field records.

### *Selecting a Project*

The first time Trac Mate is opened, you will be prompted to select a project or client. However, projects/clients can be changed at any time by selecting the **Change Project** button.

If multiple projects/clients have been synchronized with Trac Mate, make sure the desired project/client has been selected before recording farming operations.

To select/change a project:

1. Select the **Trac Mate Job** or **Unfinished Jobs / Workorders** button.
2. Select the **Change** button. The Data Folder box will display the location of the project files. Select the correct location and then the Project box will display all projects and/or clients that were synchronized from Trac+ or Site Pro to Trac Mate.
3. Highlight the desired project/client.

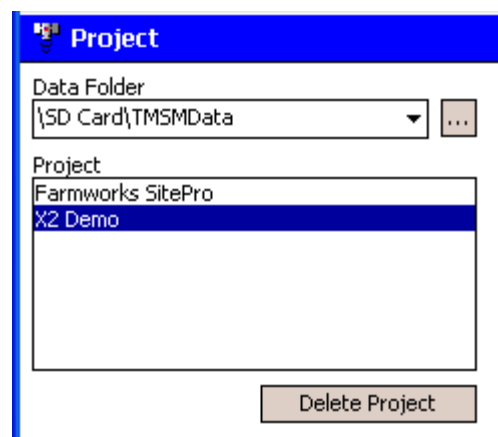

4. Select **OK**.

You can also delete a project or client from Trac Mate by selecting the **Delete Project** button.

### ***New Job Screen***

This screen allows you to select the field, crop, type, and data for a new Trac Mate job.

- **Field** – The farming operations will be performed on the field that is selected here. All fields entered on the desktop will be available for selection from the drop down lists.
- **Crop** – The current crop enterprise that is active in the field. Once the field is selected, the corresponding crop will be displayed based on what was entered on the desktop. This value may be changed if needed.

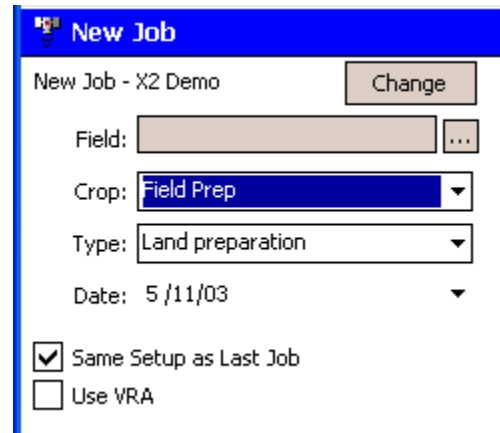

- **Type** – The Type item describes the farming operation that will be recorded. A job cannot be started until a Type has been entered.

Note: There will be an **Add/Edit** option available for each of the above items. This allows new information to be added to Farm Trac Mate. New items can be added and items that are already listed may be edited or deleted. This will update to the desktop when Trac Mate is synchronized.

- **Date** – Date that the farming operation took place. This defaults to the current date, but can be changed if needed.
- **Same Setup as Last Job** – Check this box if performing the same operation as the last job. This will save time if using the same people, equipment, supplies, etc. as the previous operation.
- **Use VRA** – If Trac Mate has been installed with Farm Site Mate – VRA and you want to variable rate a product or create an as-applied map, check this box.

### ***Job Setup Screen***

Items that will be used for the Trac Mate Job are selected on this screen.

## People

Choose the **People** button to select the person(s) that will be used in this job. People that have already been entered on the desktop prior to synchronization will be displayed in the list. Highlight the desired person and select **OK**.

You can also add, edit, and delete people in Trac Mate by selecting the appropriate button. These changes will take effect in the desktop software the next time Trac Mate is synchronized.

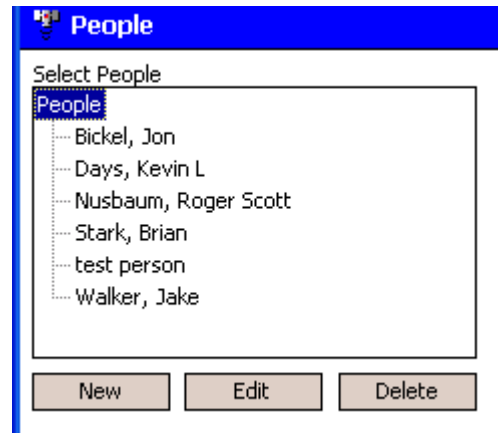

## Equipment

Press the **Equipment** button to select equipment being used in the Trac Mate job. Previously entered equipment will be available from the list. Simply highlight the desired equipment and select **OK**. Equipment must be added to a job before supplies can be added.

You can add equipment that has not been added to the program as well as edit any equipment properties or delete a piece of equipment. When adding the equipment, you must enter the properties of that piece of equipment. For information on setting up equipment properties, see the Farm Trac+ manual.

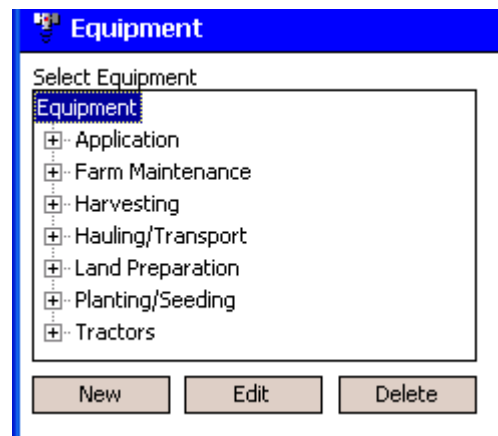

## Supplies

At least one piece of equipment must be added to the job before supplies can be added.

To use a supply in an operation:

1. Highlight the equipment that will be applying the product and then select the **Supplies** button.
2. Open the desired supply type and highlight the name of the supply to be used. All supplies that were entered into Farm Trac+ prior to synchronization will be available in this window. Press **OK** to add the supply to the job.

## Farm Works Mate X2 Reference Guide

Note: You may add, edit or delete a supply from this screen.

3. Once the supply has been selected, you will be prompted for the Initial Quantity and the Expected Rate. When you enter the Initial Quantity and Expected Rate, the Expected Area of coverage will automatically be calculated.
4. The **Fill** button will later allow you to create additional batches using the same rate for the next tank mix.

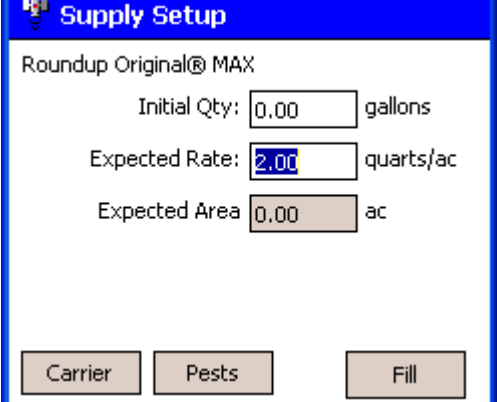

Note: The Initial Quantity and Fill options area not required. They only need to be used if you want Trac Mate to track the quantity of each supply that you have left at any time during an operation.

5. If selecting a chemical supply, there will be a **Carrier** and a **Pests** button available.
  - a. Select the **Carrier** button; choose the carrier and the carrier rate in the next screen.

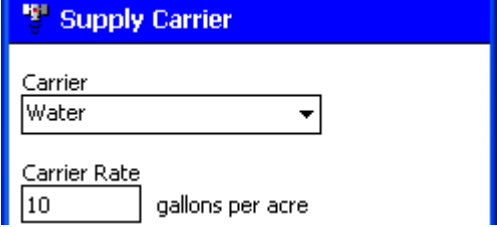

- b. You can edit the pests that the chemical controls by selecting the **Pest** button and adding new pests to the list.
6. Once a supply has been added to the Job Setup screen, its properties may be changed by double clicking the supply name and making the appropriate changes.

### Harvested Crop

If harvesting, select the **Harvested Crop** button to select the crop enterprise being harvested. If the enterprise does not exist, you may add it and set it up at this time. The harvested crop icon should be added to any operation that involves harvesting a crop. This selection will allow you to enter scale tickets or the total yield for an operation.



Items can be removed from the Job Setup screen by highlighting the unwanted item and selecting the **Delete** button.

To save the Job Setup information, select **OK**.

### Application Width

A dialog box will appear asking for the Application Width. If not using Site Mate, this value may be left blank.

### The Job Tab

Once all of the desired items for a Trac Mate job have been selected on the Job Setup window, the selected items will be displayed in the Job tab.

- **Line 1:** Displays the name of the project that you are working in and the date of the operation.
- **Line 2:** Displays the field name and the start time.
- **Line 3:** Displays the current enterprise in the field and the operation type.
- **Line 4:** Displays the Region(s) and the Region Area.



The large box in the middle displays the items (people, equipment, and supplies) that were selected for the operation.

There will be a Field Conditions, Weather, and Notes option available at the bottom of the box. By tapping on these items, you will be able to enter the applicable information.

- Field Conditions include growth stage, application method, soil condition, and soil type. There will be a pre-set list included for each item, but you may also add/edit the lists to suit your own needs.
- Weather Information includes temperature, relative humidity, sky conditions, and wind speed, gusts, and direction.

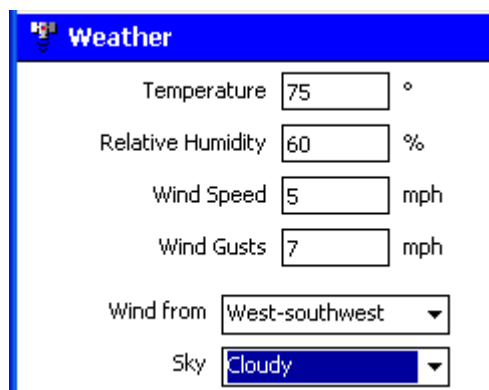
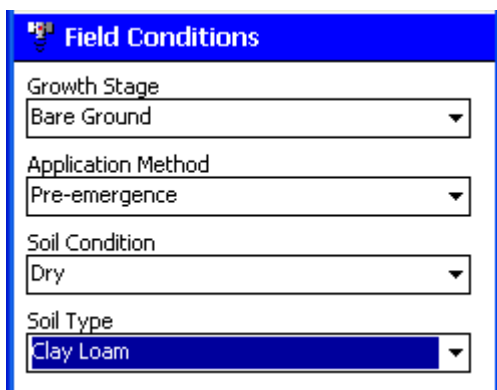

- The notes option allows you to add additional notations to the operation. The standard farming operation notation will still automatically be generated. These notes can be helpful for noting any broken tile, weed problems, or insect problems. When Trac Mate is synchronized with the desktop, these notes will be added to the Notations Report.

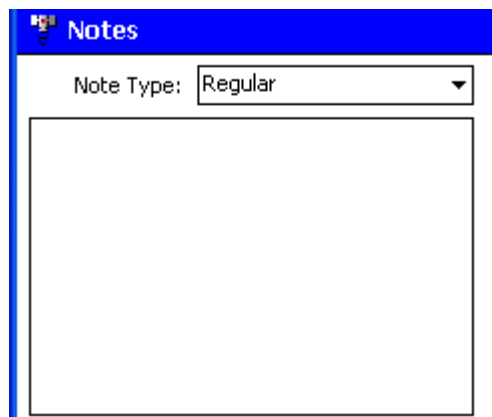

Beneath the job box, you will see several buttons – Go, Layers, Change, and Finish.



**Go** – Once selected, this button will change to **Stop**. If Site Mate is being used along with Trac Mate, this button will tell Site Mate to start/stop logging.

**Layers** – This is only available if you are using Site Mate. This button will display the log file currently being created in Site Mate and will allow you to load a background layer. This is useful if you wish to display another map such as a soil type or yield map.

**Change** – Allows you to add or remove people, equipment, and supplies from a job. Selecting this button creates a new region for the job. Selecting **Change** will prompt the **Change Operation** screen to appear and you will be asked for the following information:

**Area Since Last Change** – area covered since you started the operation or since you made the last change. This becomes the area of the region being completed. This will be automatically calculated if using Site Mate with GPS based off of the area covered.

**Total Area** – sum of all areas including the area entered in the Area Since Last Change. This includes all regions.

**Field Size** - total acreage of the field. This is the same acreage that is used from the Tillable Area in the properties of the field.

**Finish** – Gives the option to mark a job as Finished or Incomplete. More will be covered on finishing a job in a later section.

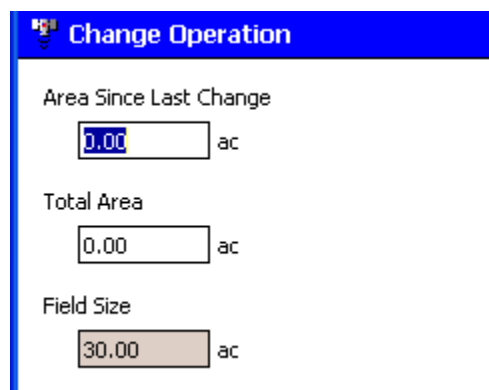

## Adding/Removing items from a current job

To modify the items being used in the current job, you must select the **Change** button to end the current region and begin a new one.

1. Once the **Change** button has been pushed and the area has been filled in, highlight the supply to remove from the job.
2. Select the **Delete** button and the Units Charged screen will appear. If it is a supply, it will show the quantity used based off of the rate and the area covered. Otherwise it will ask you to fill in the charge units for the item being removed.

Units Charged			
Supplies			
Starting	Added	Ending	Used
Roundup Original@ MAX (gallons)			
59.75	0.00	39.75	20.00

To add a different supply, person, or equipment to a job:

1. If adding a supply, first highlight the equipment that the supply will be used with.
2. Select appropriate category icon: personnel, equipment, supplies, harvest  

3. Select the item you would like to add from the list. If the item you want is not in the list, you can add it by selecting the **New** button at the bottom of the screen.
4. Select **OK** to add the item to the job.
5. If adding a supply, you will be prompted to enter the Expected Rate for the supply being used.
  - a. Select the Carrier and Pests, if applicable.
  - b. To track the amount of the supply at any time, select the **Fill** button to enter the amount of the supply loaded into the equipment.
  - c. Select **OK** to save the information for the supply.
6. Select **OK** to add the item to the job.

## Entering Harvest Data with Scale Tickets

Whenever the Harvested Crops icon is added to an operation, you can enter total yield or scale tickets for the current operation. To enter harvest information with scale tickets,

## Farm Works Mate X2 Reference Guide

simply select the harvested crop icon from the Job tab and enter the scale tickets from the operation.

1. Select the Harvested Crop icon  on the Job tab once the job has been started in Trac Mate.
2. Tap on the **Scale Ticket** button.
3. To add a new scale ticket, select the **New** button.
4. Enter the Load ID as well as the Gross and Tare weights, Moisture, and FM percentages.
5. Select the **Crop Setup** button to view/edit the density of the harvested crop as well as the shrink schedule

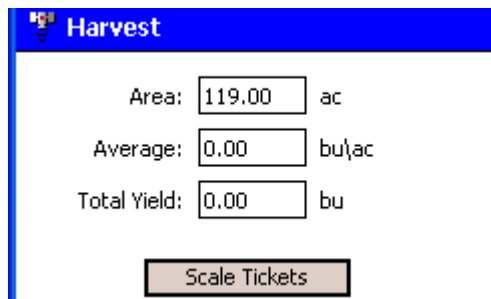

The Harvest screen displays the following fields:

- Area: 119.00 ac
- Average: 0.00 bu/ac
- Total Yield: 0.00 bu
- Scale Tickets button

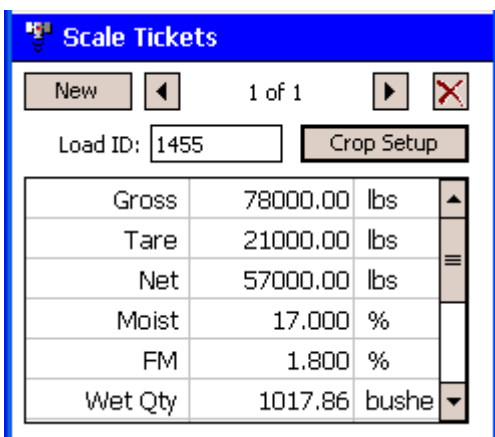

The Scale Tickets screen displays the following fields and table:

- New button
- 1 of 1
- Load ID: 1455
- Crop Setup button

Gross	78000.00	lbs
Tare	21000.00	lbs
Net	57000.00	lbs
Moist	17.000	%
FM	1.800	%
Wet Qty	1017.86	bushe

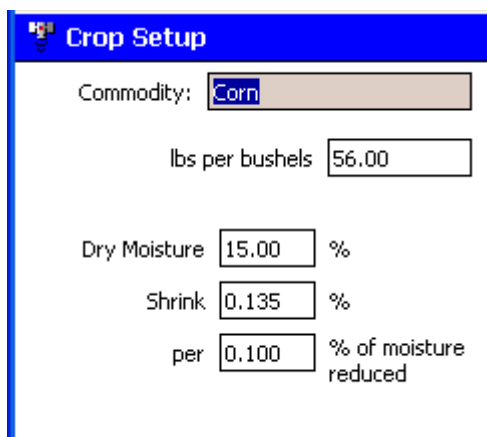
The Crop Setup screen displays the following fields:

- Commodity: Corn
- lbs per bushels: 56.00
- Dry Moisture: 15.00 %
- Shrink: 0.135 %
- per: 0.100 % of moisture reduced

6. Select **OK** to accept this scale ticket or **New** to add an additional ticket.
7. Scale tickets may be viewed/edited by selecting the Scale Ticket button and using the arrows to scroll to the desired scale ticket.
8. You may delete a scale ticket by selecting the **Delete** button while viewing the unwanted ticket.

### Entering Yield Data without Scale Tickets

Yield data may also be added to Trac Mate using the average yield or total yield for the current operation. To enter yield data without scale tickets:

1. Select the Harvested Crop icon  from the Job tab.

2. Enter the area harvested.
3. Enter the Average Yield or the Total Yield and the other will be calculated automatically based off of the area harvested.
4. Select **OK** to record the harvest information.

### **Finishing a Job**

1. Whether the job is complete or incomplete, select the finish button at the bottom of the Job tab.

**Finished** – tells the program that the operation is complete and ready to synchronize to the Farm Trac+ project or Site Pro client. You will not be able to view this operation until it has been synchronized.

**Incomplete** – Tells the program the operation is not complete. This operation will be available as an Unfinished Job/Work Order. An incomplete job will not synchronize to the main project.

Note: It is recommended that jobs that will be completed on a different date or have other jobs performed in the meantime be marked as finished.

2. When you mark a job as **Finished**, you will be prompted to enter the area since last change and/or total field area.
3. You will then be asked to enter the charge units for the people, equipment, and supplies for the job.

	Starting	Ending	Used
<b>Charge Units</b>			
Walker, Jake (hours)			2.48
Spray Coup (acres)			10.00
<b>Supplies</b>			
	Starting	Added	Ending
Atrazine 4L (gallons)	0.00	5.00	0.00

The **Units Charged** screen will display the units charged for the people, equipment and supplies, as well as the quantities for each of these items. This information will be linked to the information entered previously, but can be edited here as well.

**People** – typically charged by the hour, this is the total time spent on the job. Trac Mate will compute the total hours worked starting when you select the **Trac Mate Job** or **Unfinished Job/Workorder** button in the Job tab. The time will end when you select the **Finish** button in the Job tab. When an unfinished job is selected, the program will add to the number of hours previously logged.

**Equipment** – If equipment was set up as *metered*, the starting quantity will already be displayed on this screen. You will also be able to view the starting and ending meter entries. If you are not using the metered option for this equipment, the total units will have to be entered.

**Supplies** – This screen will display the starting, ending, and total quantities used for each supply as well as any amount added throughout the job. These values will already be displayed if using based on area covered and quantities entered during fills, but they can be edited here as well.

### ***Unfinished Jobs / Workorders***

There are two different ways to get an operation to display under the **Unfinished Jobs / Workorders** button.

1. **Planned Jobs** – Planned jobs that are created in Farm Trac+ or Site Pro can be exported and made available as a Workorder. Planned jobs are exported from the **Jobs** tab on the desktop software by right clicking on the planned job. When the Trac Mate synchronization process is completed, the Planned Jobs will be found as Work Orders in Trac Mate. This operation can then be completed in Trac Mate. Your Farm Trac+ manual has more information on creating plans / workorders.
2. **Incomplete Trac Mate Job** – When a Trac Mate job has been started and marked as **Incomplete**, the operation is saved to be re-opened at a later date for completion.

### **Opening an Unfinished Job / Workorder**

1. Select the **Unfinished Job / Workorder** button on the Job tab.
2. Highlight the desired unfinished job / workorder.
3. Select **OK**.

Note: If you do not see the desired workorder / unfinished job, make sure the correct project is selected by tapping on the **Change Project** button. See the *Selecting a Project* section of this manual for detailed steps on changing projects.

4. Once the Unfinished Job or Workorder has been opened, the Job tab will display the operation. The selected job may be edited. Refer to the Job Tab Section of this manual for detailed instructions.

## Using Trac Mate (with Site Mate)

Using Site Mate in conjunction with Trac Mate allows you to map coverage and, if VRA is installed, send rates to a variable rate application controller via a map. Using Site Mate requires the use of a GPS receiver for positions.

To create coverage maps while performing a Trac Mate job:

1. Follow all of the steps of using Trac Mate without Site Mate through the Job Setup Screen.
2. Be sure to enter the actual Application Width of your implement when prompted.
3. Once the job has been started, you can go to the Map tab in Site Mate and the field boundary for the selected field should be displayed. If you are located within the field, have a GPS signal, and the GPS unit is connected properly, the position indicator should show where you are located inside the field boundary.
4. The **Go** button on the Map tab performs the same function as the **Go** button on the Job tab. Press one of these buttons when you want logging to begin.
5. Site Mate will now log coverage wherever you go in the field until you press the **Stop** button. If an implement switch is connected, coverage will stop when the implement is up or off. See the *Advanced Logging Options* section of this manual for settings on connecting an implement switch.

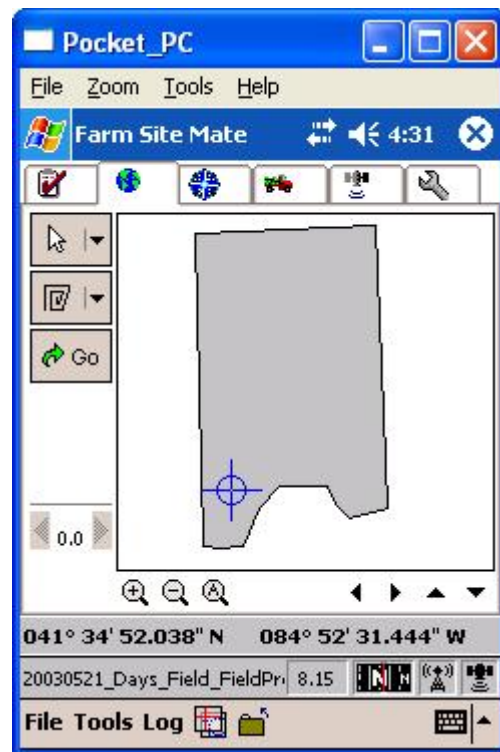

6. Trac Mate will then use the area calculated by the coverage map while recording the job. The area will show on the bottom of the Map tab as well as in the Region Area on the Job tab.
7. This area will be entered into the correct locations when changing regions and completing fields. You will, as before, be able to modify the area value. All inputs that are based on area (charge units and supply rates) will be computed off of this number as well.
8. Finish a job (finished or incomplete) just as you would if not using Site Mate.



## Using Site Mate

### *Tools and Indicators*

There are several tools within Farm Site Mate that make data entry and data monitoring easier. The following tools are available from the Tool button at the left of the Map tab or by selecting the **Tools** menu within Site Mate.

- **Pointer Tool:** Used for selecting lines or objects. Users may also use the pointer tool to right click on a line or object and view the right click menu.
- **Manual Coordinates Tool:** Used when the GPS Source has been set to Manual Location Entry.
- **Navigation Tool:** This option is only available with Farm Site Mate-Scouting and VRA. The Navigation Tool is used to navigate to a selected point. See the section on Scouting Features for more information.
- **Measure Tool:** Used to measure the length of a line. Simply select this tool from the Tool button and click and drag the line to be measured. The length will be displayed to the left. If you need to measure more than one line segment, select the *Sum* box and click at every line segment.
- **Zoom Tool:** Used to zoom (in or out) on a map. Once selected, a left click will zoom in on the selected area and a right click will zoom out. You can also click and drag around an area to zoom in to it.
- **Align GPS:** This option is used to shift a map to compensate for GPS drift. If a background map appears to be shifted, you can go to a known point and shift it to where it is suppose to be. You cannot Align a map that is being logged to.

The **Tools** menu also allows users access to the zoom options. These options are also available as buttons at the bottom of the Map tab.

- **Zoom In:**  Zooms in on the current map by 2x each time selected.
- **Zoom Out:**  Zooms out from the current map by 2x each time selected.

- **Zoom All:**  Zooms in or out from the map so that all information currently displayed is displayed on the screen.

Site Mate also provides several indicators to make data collection easier while you are in the field.



- **Speed:** Site mate will display your current speed at the bottom right corner of the screen
- **Compass:** The current heading will also be displayed at the bottom of the screen.
- **GPS and Differential Indicators:** If the option to *Show GPS and Differential Indicators* was selected on the Config tab, these indicators will be activated when receiving GPS and/or Differential. If the option to *Show Number of Satellites and HDOP Indicators* was selected, the appropriate values will be displayed at the bottom of the screen.

## Job Tab

The Job tab of Site Mate is where you will decide the type of operation you are completing.

- **Trac Mate Job:** This button is only available if Trac Mate is installed. Select this option to begin a Trac Mate job that allows you to select the people, equipment, and/or supplies to be used in a farming operation. See the Trac Mate section of this manual for more information.
- **Scouting Job:** Select this option to complete a typical Site Mate job. Users will be able to create a new or load an existing .fgp or .gpl file as well as load background maps. This is used for any basic mapping functions.
- **Sensor Job:** This option is only available if Site Mate-VRA is installed. Select this option to use a variable rate controller along with Site Mate to create a coverage and as-applied map. This option will not allow you to load a variable rate prescription map.
- **VRA Job:** This option is only available if Site Mate-VRA is installed. Select this option to use a Site Mate to load a variable rate prescription map and send the rates to a controller.

- **Unfinished Jobs / Workorders:** This option is only available if Trac Mate is installed. Select this option to complete any unfinished Trac Mate jobs or exported planned jobs (work orders).

## Map Tab

The **Map** tab allows users to view the map as it is being created.

Once an application log has been loaded or created, the **Map** tab will contain several pieces of information that are helpful while logging data.

At the side of the screen there are three buttons.

The first button is the **Tool** button. This button supplies a short cut for selecting tools within Site Mate. Tools may also be selected from the **Tools** menu. Tools available for selection include Pointer, Manual Coordinates, Navigation, Zoom, Measurement, and Align GPS.

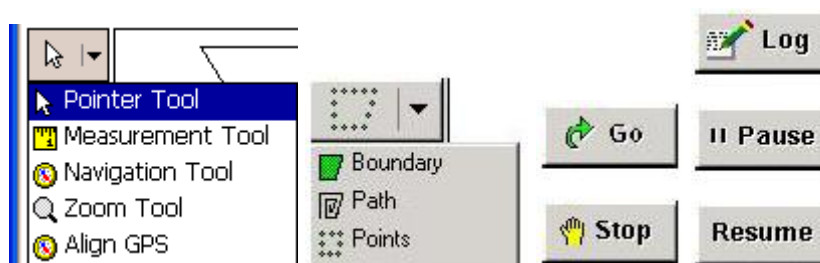
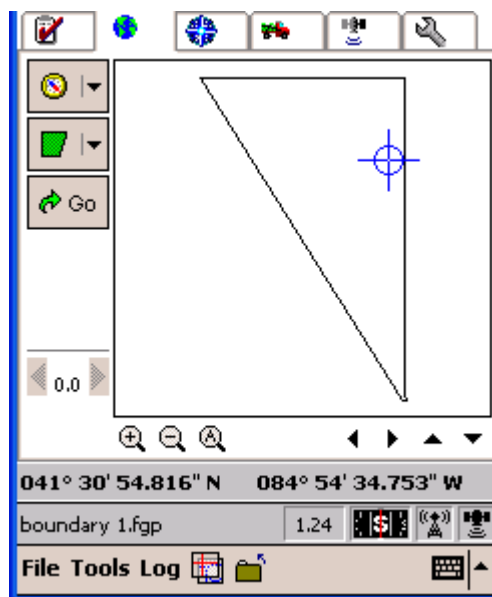

The second button is the **Log Type** button and refers to the type of data that will be logged. Users will be able to select Path, Points, or Boundary. Select the desired type before beginning the job.

The third button is the **Go** button. The **Go** button tells Site Mate when to begin logging data. Once selected, **Go** will change to **Stop**. Select **Stop** when the logging is complete.

Once **Go** is selected, an additional button will appear – either **Pause** or **Log**. If you are manually logging data, a **Log** button will appear. Each time that you want Site Mate to log data, select the **Log** button. If you are logging data automatically, **Pause** will appear. The **Pause** button is used to stop logging data temporarily. Once selected, **Pause** will change to **Resume**. Select **Resume** to begin logging again. When **Resume** is selected, your current position will connect the position where **Pause** was originally selected. **Pause** is useful when there is an obstruction in your direct path that you need to travel around, but do not wish to leave a gap in the line or boundary.

The Offset indicator is also located at the left side of the screen. This will display the current offset, if applicable, as well as the direction of the offset. Users may tap on this to change the current offset.



Across the bottom of the Map tab are useful viewing tools – zoom and scrolling tools. The four arrows at the bottom right allow you to move the screen in the indicated direction.

A screenshot of the 'Offset' settings screen. The title bar is blue with the word 'Offset' in white. Below the title bar, there are two sections: 'Horizontal Offset' and 'Vertical Offset'. The 'Horizontal Offset' section has a text input field containing '0' followed by the word 'feet'. To the right of this are three radio button options: 'Left', 'Right', and 'No Offset', with 'No Offset' being selected. The 'Vertical Offset' section has a text input field containing '0' followed by the word 'feet'.

### **Data Tab**

The **Data** tab displays information related to the current GPS signal. Users can select different NMEA strings that they would like to view information on in this tab. Note: The GPS receiver must be outputting the selected string for data to be viewed.

### **Scouting Job**

The Scouting Job button on the Job tab allows users to start a new log file and/or load a background map. To open an existing log file, select the Open button next to the Scouting button and browse for the log file.

To create a New Log File:

1. Select **New Scouting Job** from the Job tab.
2. Enter the name of the new file.
3. Select the location for the file to be saved from the Folder window. You need to save the file in either the TMSMData/Scouting folder or in My Documents for Farm Site to be able to synchronize the job.
4. Select **OK** to accept the new file name and location. If using Site Mate Scouting or VRA, the Template Screen will appear, otherwise skip the next 2 steps.
5. The Template screen allows users to add a template to the log file. Templates allow users to link attributes to a log file. Select the desired template from the list or create a new template. For more information on creating templates, see the Configuration Section of this manual. If no attributes are desired, select “No Attributes”.

6. Select **OK** to accept the template. You will be taken to the Map tab and will be ready to begin logging information.

## ***Loading Background Files***

Site Mate allows you to load an unlimited amount of previously created maps behind the current log file. This is called a background map.

1. Select the **Layers** button from the bottom of the Map tab.
2. Browse to the location of the saved background and highlight the desired file. Backgrounds can be .shp (shape files), .bmp (image), or .smb (site mate batch).
3. Select **OK** and you will be taken to the **Background** screen where the selected background will be listed.
4. To open more background layers, select **Open** from the drop down list and repeat the last 2 steps.
5. Once a background layer is loaded, there are more options in the drop down list. Highlight the background layer that you want to change the options for.
  - a. **Legend:** Select this option if you would like to view a legend for the selected background. Users will be able to select the data item they wish to create the legend for as well as the color for each range.
  - b. **Label:** Select this option to display a label for the selected background. Users will be able to select which attribute(s) will be displayed in the label and whether the label will be transparent or opaque.
  - c. **Close:** Select this option to remove the selected background from the display.
  - d. **Close All:** Select this option to remove all backgrounds from the display.
6. Select **OK** to accept the listed background maps. You will be returned to the map screen.

Once the log file and backgrounds have been loaded, you will need to decide what mode of logging you will be using: manual or automatic.

## ***Manual Logging***

Manual logging is typically used for logging sample points and allows users to tell Site Mate when and where to log a point.

## Farm Works Mate X2 Reference Guide

To manually log points once a scouting job is open:

1. Select **Manual** from the Log menu at the bottom of the Map tab.
2. Select the desired log type from the button at the side of the screen (Boundary, path, or point).
3. Select **Go** and the **Log** button will appear.
4. Travel to the location of your first point and select **Log**. The attributes window will appear if you selected a template when starting the job.
5. Enter the attributes, if applicable and select **OK** to accept the logged point.
6. Log all additional points and select **Stop** when finished.

Boundaries and paths may be logged manually as well. To do this, you will select **Log** at the starting point of the line or boundary and then select **Log** at each direction change (corner) of the field. Each time that **Log** is selected (after the initial time) a straight line will be drawn between the previously logged point and new logged point.

### ***Automatic Logging***

Automatic logging is most commonly used for logging boundaries and paths. It will create the map as you are traveling through the field.

To automatically log data once a scouting job is open:

1. Select **Automatic** from the Log menu at the bottom of the Map tab.
2. Select the desired log type from the button at the side of the screen (Boundary, path, or point).
3. Select **Go** to begin logging data. The **Stop** and **Pause** buttons will appear.
4. Site Mate will begin logging data according to the recording intervals set in the Config tab.
5. Select **Pause** to stop the logging process temporarily.
6. Select **Stop** when the scouting job is complete.

Once the log file is complete, you are ready to close the file and synchronize it to your main computer. To close a file, go to the Job tab and select the **Close Job** button. Depending on your settings in the config tab, you will be asked if you would like to export the log file and what type of export you would like to create.

Note: You do not need to export the log file if you plan to synchronize Site Mate using the **Synchronize Trac Mate** option within Trac+ or SitePro.

## Other Site Mate Basic Features

### Grid Sampling

Site Mate makes grid sampling easier by allowing users to create the grids in the field. To create a sampling grid:

1. Either load the boundary of the field to be gridded as a background map or log the boundary to create the boundary map.
2. Select the **Pointer Tool**.
3. If you have a laptop computer, right-click on the boundary. If you have a Windows CE device, tap on the boundary.
4. Select **Grid Area** from the pop-up menu.
5. In the **Create Sampling Grid** window, enter the size, shape, and pattern for the grid.
6. Select the **OK** button to return to the map.
7. Click/tap on the starting corner of the field, then drag the cursor along the boundary in the direction that the grid points are to be arranged.

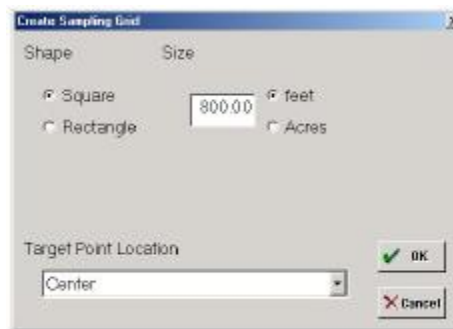

Note: The line that is created here will be used to create the alignment of the sampling grid.

8. When you release the mouse (or lift the stylus), the field will be gridded.
9. Buttons on the left of the map may be used to modify the grid. **Setup** allows you to modify the size and pattern options previously set. **Rotate** allows you to click and drag again to get a different angle of grid squares. **Move** allows you to drag the entire grid around on the map to obtain the best alignment.
10. Press the **OK** button to accept the current grid alignment. Pressing **Cancel** at any time will abort the gridding process.



- Options will be given to create Points, Lines, and/or Polygons in each grid cell. Check the appropriate boxes and select whether you want the gridded data saved as an ArcView Shape file or Map Info Interchange file (Shape is the most common.) Each object type will be created on a separate layer and saved.

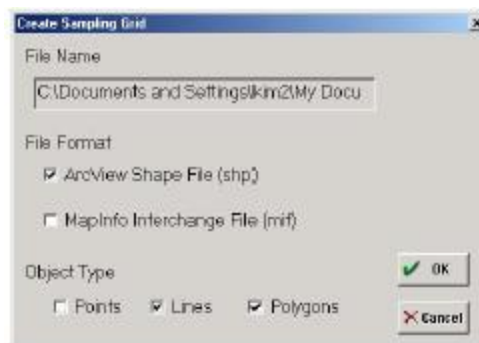

Note: Grid points will be circular, so they can easily be distinguished from logged points (which are squares).

## Manual Location Entry

The Manual Location feature is useful for creating maps when you cannot physically map the location with a GPS receiver.

- When you are ready to map a location manually, select **GPS settings** from the **File** menu or select the **GPS settings** option in the **Settings** area of the **Config** tab.

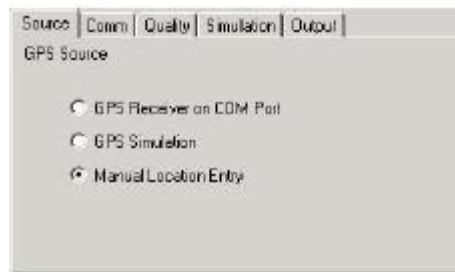

- Change the **GPS Source** to *Manual Location Entry*.
- Select the type of data that you wish to log manually (boundary, path, or point).
- Select the **Manual Coordinates Tool** from the tool button.
- Select the **Go** button to start logging.
- Tap or click at the position where you wish to log. If you are logging a point, it will be displayed on the screen. If you are logging a boundary or a path, they will be drawn as you click each corner.



Note: Manual Location Entry uses the same logging intervals as if using a GPS receiver.

- Select the Stop button to finish mapping the feature. Close and/or export the log file as normal.

You can also enter a known coordinate for a manually located point. Log the point, then click/tap on the **Tools** menu and select **Enter Coordinates**. Enter the coordinates for the logged point and select **OK**.



## Other Site Mate Scouting Features

### Navigate to Point

Site Mate Scouting (and VRA) adds the ability to navigate to a known point. This is very useful when collecting soil samples. Being able to navigate back to a known point allows users to navigate to the sampling points created by the grid sampling process of Site Mate.

1. Use the **Zoom Tools** to view the area that you want to navigate to.
2. Select the **Navigation Tool** from the **Tool** button on the left.

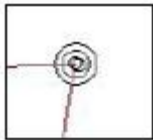

3. With this tool selected, you may navigate to any point by clicking/tapping on the map at that location. A bulls-eye will appear at the selected location/point.
4. You can also click/tap on a point already on the map and select **Navigate To Point**.
5. A navigation dial will appear on the screen. The vertical line at the top of the dial represents the direction that you are traveling. The moving arrow represents the direction that you need to go to reach the target. The distance to the target point will be displayed below the dial.
6. To see a larger view of the navigation dial, click on it in the bottom left side of the screen and select **Swap Navigation and Map**. To return to the map, click on the larger navigation dial and select it again.
7. Click on the “x” above the navigation dial to close navigation.



## Performing a New Sensor Job

## Farm Works Mate X2 Reference Guide

With Site Mate VRA, you can log what a variable rate controller is doing and create an “as-applied map”. If you do not have a variable rate map that you want to control by, but want to log the applied rates, use the **New Sensor Job** option.

To start a New Sensor Job:

1. Verify the Variable Rate Setup information is correct for the controller you are using as well as the Advanced VRA Options. See the Settings section of this manual for more information on the Variable Rate Setup.
2. Select **New Sensor Job** from the job tab, or if using Trac Mate, just start a new **Trac Mate Job** and check the box beside **Use VRA**.
3. If using Trac Mate, proceed through the Job Setup and Application Width screens as explained in previous sections and it will then prompt you for Variable Rate Layers.
  - a. Check the *Log without Control* option and the Rx Map box will be grayed out. The Application Log file will be filled in automatically based on the field, crop, job type, and data.
  - b. Select **OK** and the job will be opened.
4. If you are not using Trac Mate, when you select **New Sensor Job**, it will prompt you for a file name to log to. Enter the file name and select **OK** to open the job.
5. If you are not using Trac Mate, it will prompt you asking for a template to use. If you want to use a template, select or create one here or select <No Attributes> if you do not want to use a template. For information on creating templates, see the appropriate section of this manual.
6. On the map tab, on the left side of the screen, you will see a **Setup** button, a **Go** button and two boxes – *Target* and *Applied*. Select the **Setup** button and make sure that the correct controller is selected for this job. You may also enter a new controller setup or edit an existing one at this time.
7. Select **Go** to begin the sensor job. Once the job is started, the Target box will display a -1 since you are not controlling the rate from a map. The Applied box will now display the rate being applied. You will also notice the booms icon will now be highlighted.
8. Select **Stop** when the job is complete.



9. If using Trac Mate, select **Finish** from the Job tab and complete the job as explained earlier in this manual.
10. If you are not using Trac Mate, you may want to export the application log by selecting **File > Export Log**.
11. From the Job tab, select **Close Job**.

## Performing a VRA Job

If you have an Rx map that you want to use to send a rate to a variable rate controller, you will use the **VRA Job** button or, if using Trac Mate, just start a new **Trac Mate Job**.

To start a VRA Job:

1. Verify the Variable Rate Setup information is correct for the controller you are using as well as the Advanced VRA Options. See the Settings section of this manual for more information on the Variable Rate Setup
2. Select **VRA Job** from the Job tab. If using Trac Mate, start a new **Trac Mate Job** and check *Use VRA*.

- a. If using Trac Mate, proceed through the Job Setup and Application Width screens as explained in previous sections and it will then prompt you for Variable Rate Layers.

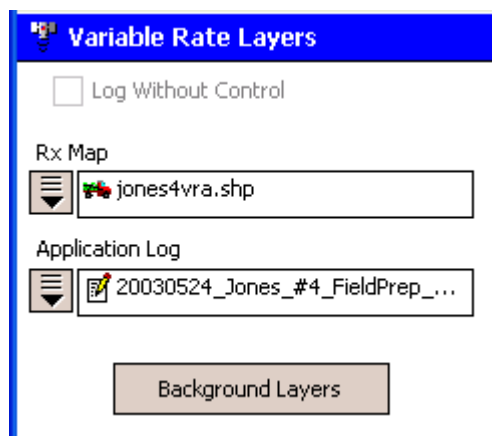

- i. Make sure the *Log without Control* option is unchecked and click the down arrow beside the Rx Map box to select Open. Browse for your Rx Map.
- b. If performing a **VRA Job** without using Trac Mate, the program will prompt you for your prescription map file. It will then ask you information about the Shape File that you are loading.

Note: Rx Maps must be in shape files which contain 3 files altogether. (.shp, .shx, .dbf)

3. Select the **Data** item contained in the shape file that you will be controlling. If the Coordinate System used to create the Variable Rate map is different than the one shown, select the appropriate one

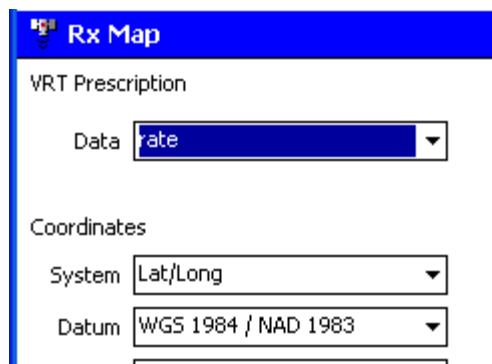

## Farm Works Mate X2 Reference Guide

and enter the Datum and Zone, if applicable. (Most programs use Lat/Long, WGS 1984)

4. Select **OK** to return to the Variable Rate Layers screen.
5. The Application Log file name will automatically be created. You can select Open to use an existing log, if needed.
6. Select **OK** to load the Rx map, application map, and any other background files that were selected. Select the Map tab to view the Rx map and you are ready to being your variable rate application.
7. On the map tab, on the left side of the screen, you will see a **Setup** button, a **Go** button and two boxes – *Target* and *Applied*. Select the **Setup** button and make sure that the correct controller is selected for this job. You may also enter a new controller setup or edit an existing one at this time.
8. Select **Go** to begin the VRA job. The **Rx** box will display the application rate assigned to the current area of the Rx map. The **As Applied** box will display the actual rate being applied. You will also notice the booms icon will now be highlighted.
9. Select **Stop** when the job is complete
10. If using Trac Mate, select **Finish** from the Job tab and complete the job as explained earlier in this manual.
11. If you are not using Trac Mate, you may want to export the application log by selecting **File > Export Log**.
12. From the Job tab, select **Close Job**.

## Using Guide Mate

There may be times when you want guidance, but do not want to start a complete Trac Mate job. You can start a Guide Mate job by itself or after beginning a Trac Mate job.

1. If using Trac Mate while performing guidance, start the Trac Mate job entirely.

## Farm Works Mate X2 Reference Guide

2. From the Guide Mate tab, select the Swath Pattern that you would like to use. (See Swath Patterns in this manual for more information.) Also, enter the **Swath Width**. This is the width that you want to perform guidance by. If using Trac Mate, it will default to your implement width.
3. Press the Start Guidance button.
4. Depending on which swath you chose, press the button to begin your first swath and perform your guidance pattern. See Swath Patterns for more information on driving each pattern type.
5. Depending on your settings, you will use the on-screen lightbar to steer towards or away from the lights. Also use the steering needle to stay on the current swath.
6. The guidance screen will show how far off of the swath and in which direction you are. The upper right hand corner will show your swath number as well as the coverage area. The right hand side of the screen also shows Target and Applied rate if using VRA.
  - a. If you are using VRA or are tied to an implement switch, the guidance arrow will turn red when logging is off and green when logging is turned on.
7. You can click on the Map tab to view a coverage map of everything you have done. You will also notice a lightbar on top of the map tab as well, so you still have guidance even when looking at the map.
  - a. If using Trac Mate and Site Mate, the field boundary will show on the map tab showing your location as well as a red line showing which swath you are on.

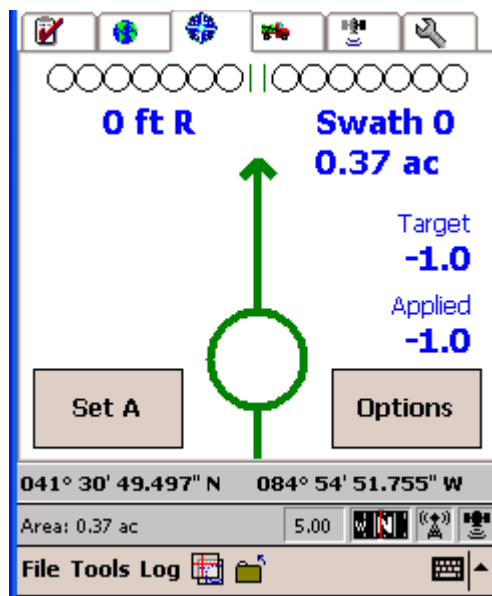

- b. The **Flag** button is located in the upper right hand corner of the map tab and places a red point on the map. This can be helpful to map rocks, blowouts, trouble areas, etc. These maps can later be imported into Farm Site to view.

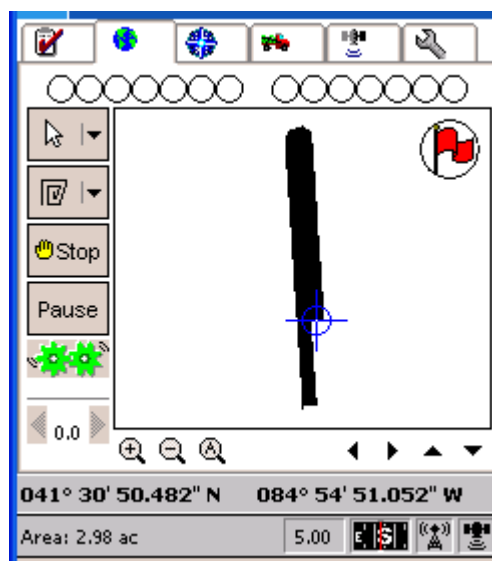

## Farm Works Mate X2 Reference Guide

8. The **Options** button is located on the Guide Mate screen.
  - a. **Reset A-B:** Allows users to clear current A-B guidance points and re-set new A-B points without closing the current job. After A-B points are cleared, return to swath guidance screen and set new A-B points for continued guidance.
  - b. **Recal A-B:** Allows user to adjust the A-B line reference and all successive swaths to this adjusted point. User must determine the precise corrected position of the current swath line and position the machine to that point. Then press “Recal A-B” then “Continue” to adjust the A-B line reference.
  - c. **Save Guidance:** Allows user to save the guidance pattern for use at a later time. This can be helpful if wanting to run the same swath for different operations within a field.
  - d. **Close Guidance:** Closes the job. Guidance pattern will not automatically be saved, once closed any unsaved patterns will be lost. If using Trac Mate, this option will not close the Job. It will allow you to close the current guidance pattern and begin another without starting a new Trac Mate job.
  - e. **Mark/Return:** After the “Mark/Return” button is pressed, GM will display distance back to the marked point, as well as show a line on the GM guidance screen to assist with returning to where the original point was marked. Press the “Mark/Return” button a second time to clear the “Mark/Return” mode.
9. If you are not using Trac Mate, you may want to export the coverage map. Go to **File > Export Log**.
10. Choose which type of file you want to export the map as. The most common choice is an *Arcview Shape File (shp)*.
  - a. You will then need to choose which layers you want to export. (Coverage is logged as paths and flags are logged as points.
  - b. When not using Trac Mate, Guide Mate will name the files according to the date created.

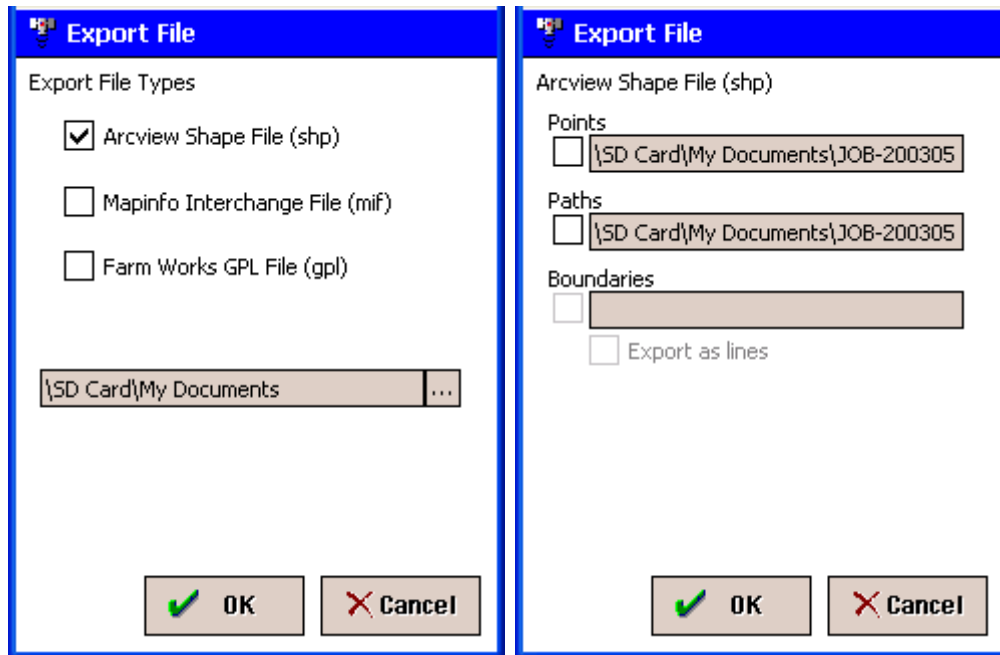

- When finished with the guidance pattern, you can either go to the Options button on the Guide Mate tab and select Close Guidance or choose Close Job from the Job tab if not using Trac Mate.

### Swath Patterns:

- Straight AB:** Guidance for straight back and forth swathing based on the first pass (two button presses required on first pass, no swath to swath button presses after the first pass). Press the “Set A” button to begin Swath #1. Continue to drive to the end of swath #1 then press “Set B”. Swath #2 will be assigned according to the direction turned after the “Set B” button is pressed. All consecutive swaths will be based on the original A-B points.

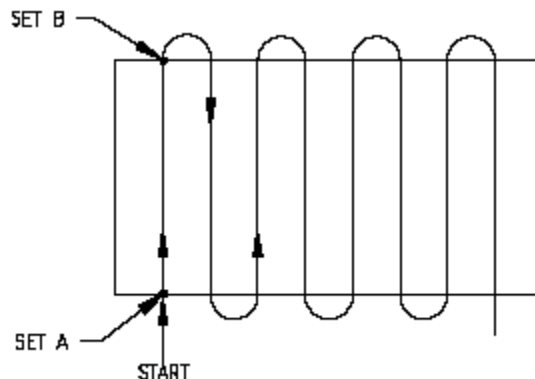

- Contour Fixed:** Guidance for curved swath patterns based from the first pass (two button presses required on first pass, no swath to swath button presses after the first pass). Press the “Set A” button to begin Swath #1. Continue to drive the

contoured swath and press “Set B” at the end of swath #1. All consecutive swaths will be based on the contour pattern of the first pass.

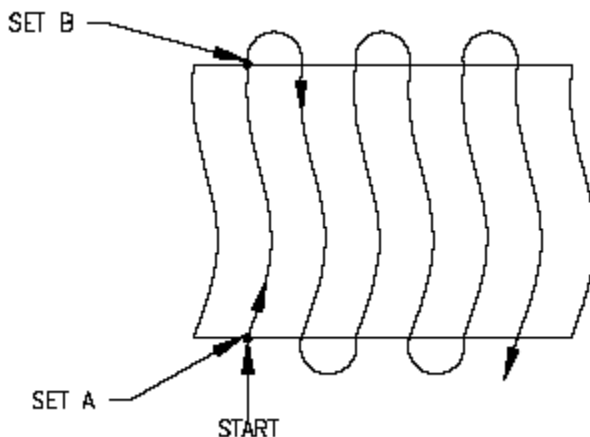

- Contour 0 Button:** Guidance for curved swath patterns based from the last pass driven (two button presses required on the first pass, no swath to swath button presses after the first pass). Press the “Set A” button to begin Swath #1. Continue to drive the contoured swath and press “Set B” at the end of swath #1. All consecutive swaths will be based on the last pass driven.

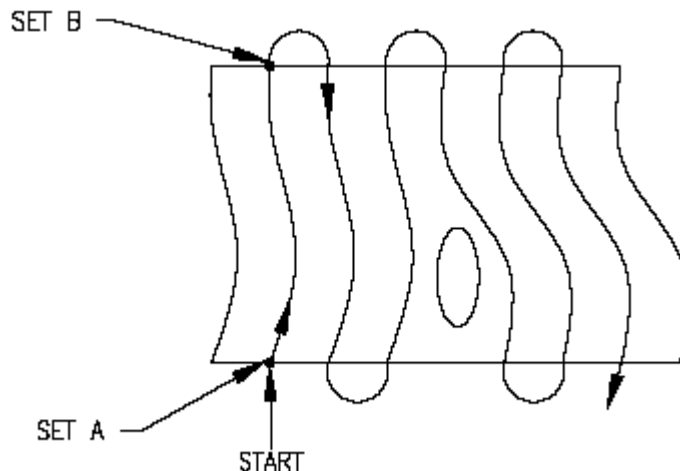

- Contour 1 Button:** Guidance for cured swath patterns based from the last pass driven (two button presses required on the first pass). Press the “Set A” button to begin Swath #1. Continue to drive the contoured swath and press “Set B” at the end of swath #1. Swath #2 will be based on the path driven in Swath #1. At the end of Swath #2, press the “Set 2B” button. Swath #3 will be based on the path driven in Swath #2. Continue these steps for each consecutive swath.

## Farm Works Mate X2 Reference Guide

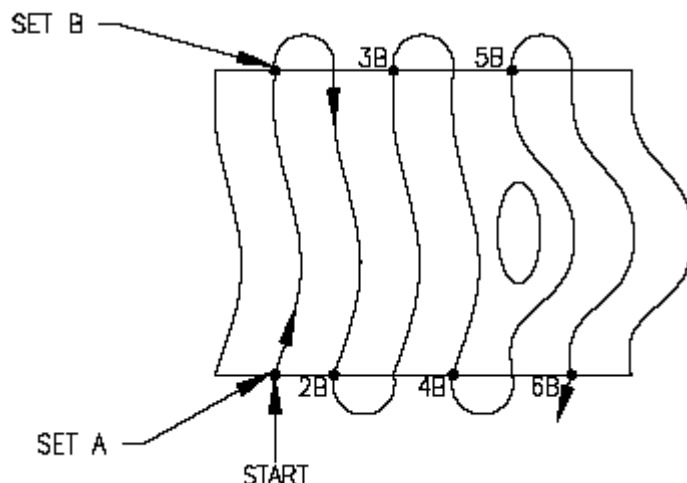

- Contour 2 Button:** Guidance for cured swath patterns based from the last pass driven (two button presses required on each pass). Press the “Set A” button to begin Swath #1. Continue to drive the contoured swath and press “Set B” at the end of swath #1. Press “Set 2A” at the beginning of Swath #2. At the end of Swath #2 press the “Set 2B” button. Swath #3 will be based on the path driven in Swath #2. Continue these steps for each consecutive swath.

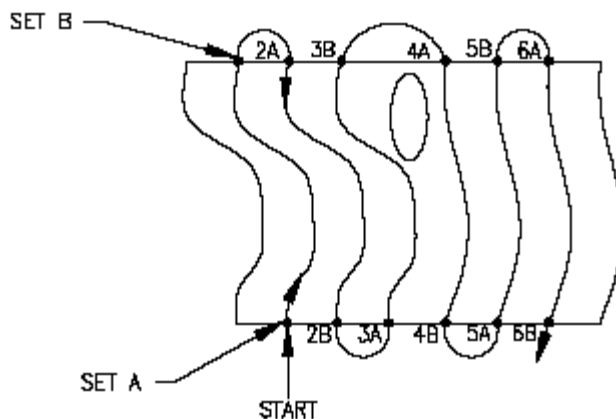

- C Clamp:** Straight pattern swathing with a double headland area on two opposite sides of the field. Enter field in direction of double headland. Press “Set CClamp 1” and drive to the end of the 1<sup>st</sup> headland pass and press “Set CClamp 2”. Turn back towards the next headland pass and Guide Mate will give guidance based on the 1<sup>st</sup> pass. Press “End Pass 2” at the end of the 1<sup>st</sup> double headland. Then turn back towards the direction in which A-B guidance is desired. Swath #1 starts after “Set A” is pressed. Continue to the end of Swath #1 and press “Set B” (guidance through the field will be based on the original A-B points). Turn towards the next headland area and press “Set CClamp 3”. Continue to drive to the end of the headland pass and press “Set CClamp 4”. Turn back towards the 2<sup>nd</sup> pass for the double headlands and Guide Mate will provide guidance down this pass. At the end of the double headland area press “End Pass 2”. Then turn towards Swath #2 and Guide Mate will provide guidance based on the original A-B points. GM will give a “distance to headland” countdown when approaching or leaving the headland areas.

## Farm Works Mate X2 Reference Guide

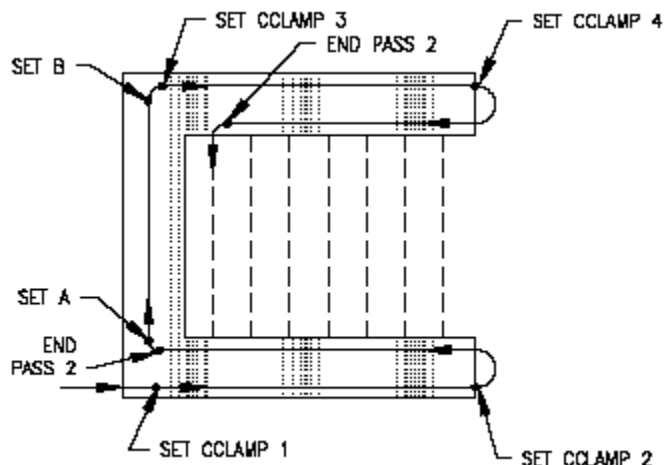

- Headland Separate:** Guidance based on straight A-B swathing with a headland area around the boundary of the field (the A-B points can be marked either within or outside of the headland area). Press “Begin Boundary” to start the headland perimeter. Continue to drive around the perimeter of the field (GM will automatically end the boundary once its position is within one boom width from the beginning boundary point). Press the “Set A” and “Set B” buttons to mark the A-B line to provide guidance for consecutive swaths through the field. GM will give a “distance to headland” countdown when approaching or leaving the headlands areas.

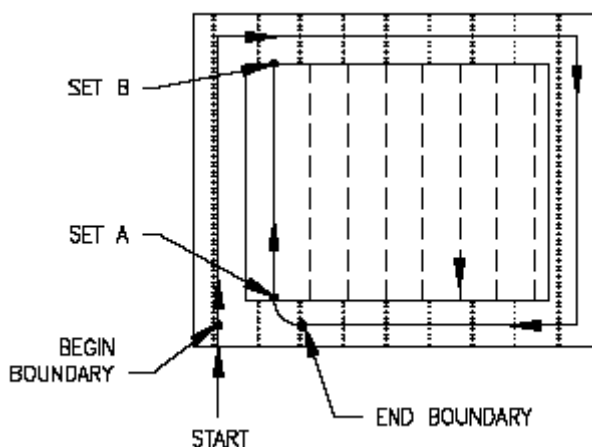

- Headlands Combined:** Guidance based on straight A-B swathing with a headland area around the boundary of the field (the A-B points are marked within the headlands area). Swath #1 (and beginning boundary) begins after “Set A” is pressed. Continue to drive to the end of Swath #1 then press “Set B”. Then continue to drive the boundary of the field (GM will automatically record the path that is driven for the headland area). Press “End Boundary” at the point when the headland boundary is complete or GM will automatically end the boundary once its position is within one boom width from the beginning “Set A” point. Guidance for consecutive swaths will be based on the original A-B points that were set. GM will give a “distance to headland” countdown when approaching or leaving the headland areas.

## Farm Works Mate X2 Reference Guide

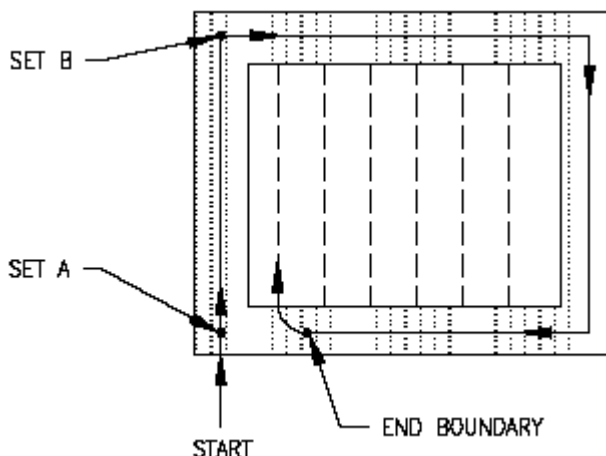

- Headlands\*2 Separate:** Guidance based on straight A-B swathing with a double headland area around the boundary of the field (the A-B points can be marked either within or outside of the headland area). Press “Begin Boundary” to start the headland perimeter. Continue to drive around the perimeter of the field (GM will automatically record the path that is driven for the headland area). Press “End boundary” at the point when the headland boundary is complete or GM will automatically end the boundary once its position is within one boom width from the beginning boundary point. GM will then provide guidance for the 2<sup>nd</sup> headland boundary. Continue to drive the boundary and press “End Pass 2” for ending the 2<sup>nd</sup> headland pass or GM will automatically “End Pass 2” once its position is within one boom width from the beginning of the 2<sup>nd</sup> boundary. Press the “Set A” and “Set B” buttons to mark the A-B line. Guidance for consecutive swaths will be based on the original A-B points. GM will give a “distance to headland” countdown when approaching or leaving the headland area.

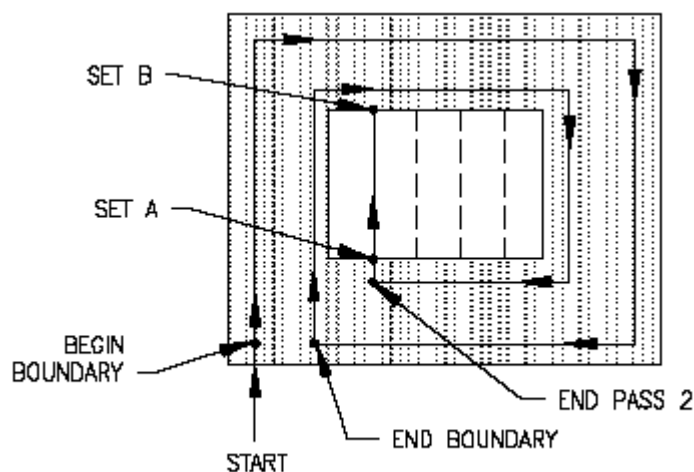

- Headlands\*2 Combined:** Guidance based on straight A-B swathing with a double headland area around the boundary of the field (The A-B points are marked within the 1<sup>st</sup> headlands area). Swath #1 (and beginning boundary) begins after “Set A” is pressed. Continue to drive to the end of Swath #1 then press “Set B”. Then continue to drive the boundary of the field (GM will automatically

## Farm Works Mate X2 Reference Guide

record the path that is driven for the headland area). Press “End Boundary” at the point where the headland boundary is complete or GM will automatically end the boundary once its position is within one boom width from the beginning “Set A” point. GM will give guidance for the 2<sup>nd</sup> headland boundary. Continue to drive the 2<sup>nd</sup> boundary and press “End Pass 2” at the end of the 2<sup>nd</sup> headland area or GM will automatically “End Pass 2” once its position is within one boom width from the beginning of the 2<sup>nd</sup> boundary. Guidance for consecutive swaths will be based on the original A-B points that were set. GM will give a “distance to headland” countdown when approaching or leaving the headlands areas.

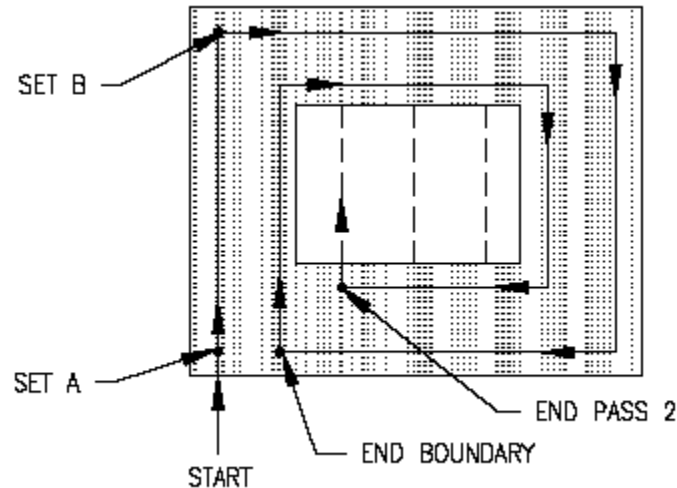

- **Headlands with Contour:** Guidance is based on 0 button contour swathing with a double headland area around the boundary of the field (the A-B points can be marked either within or outside the headlands area). Press the “Begin Boundary” to start the headland perimeter. Continue to drive around the perimeter of the field (Guidemate will automatically record the path that is driven for the headland area). Press “End Boundary” when the first boundary pass is complete (GM will automatically “End Boundary” if its position is within one boom width from the “Begin Boundary” point). Guidance for curved swath patterns based from the last pass driven (two button presses required on the first pass, no swath to swath button presses after the first pass). Press the “Set A” button to begin Swath #1. Continue to drive the contoured swath and press “Set B” at the end of swath #1. All consecutive swaths will be based on the last pass driven.
  - There is an option to set another B point, when in the guidance mode. This option only needs to be used IF STOPPING SHORT of the headland boundary. If driving to the outside of the headland boundary, the guidance system will advance automatically.
  - **Enable Snap:** The enable snap option on the screen is a feature only found in the Headlands with contour and Headlands2 with contour. The enable snap button MUST be depressed before any guidance will be provided for the pass to pass. When the headlands are completed, press the Enable snap button.

## Farm Works Mate X2 Reference Guide

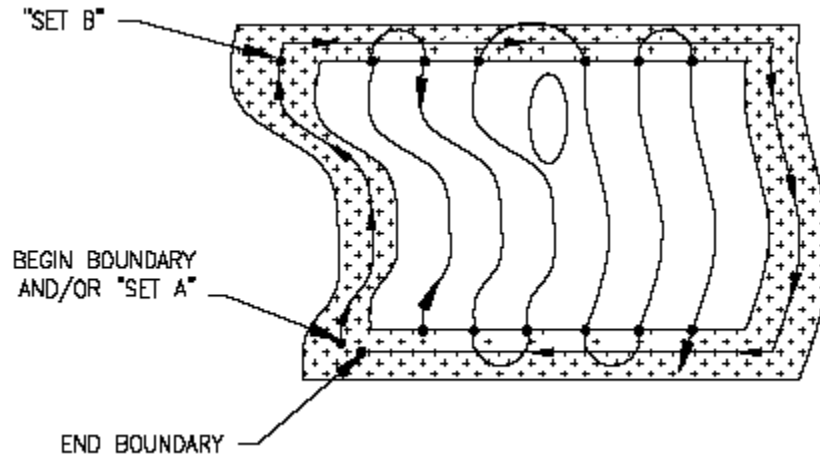

- **Headlands\*2 with Contour:** Guidance is based on 0 button contour swathing with a double headland area around the boundary of the field (the A-B points can be marked either within or outside the headlands area). Press the “Begin Boundary” to start the headland perimeter of the field. Continue to drive around the perimeter of the field (Guidemate will automatically record the path that is driven for the headland area). The A-B points can be done as the perimeter is being established. Guidance for the established A-B line will be used until the operator clears that line. **There can be multiple lines** established in a field. Clear the old line by pressing anywhere on the screen, while in guidance. Select the option “Reset A-B”. Depress the “Return to Guidance” button and the user can set a new A and B point. This option allows the operator flexibility in fields that have many erratic shapes.

NOTE: The cleared A-B line can NOT be brought back; new A-B reference points must be set in order for guidance to continue

Upon completion of the second headland, press the End Pass 2 button in order to close the second pass. Depending on where the A/B line was established, the Enable Snap option will need to be depressed to obtain the pass to pass guidance.

There is an option to set another B point when in the guidance mode. This option only needs to be used IF STOPPING SHORT of the headland boundary. If driving to the outside of the headland boundary, the guidance system will advance automatically.

- **Enable Snap:** The enable snap option on the screen is a feature only found in the Headlands with contour and Headlands2 with contour. The enable snap button MUST be depressed before any guidance will be provided for the pass to pass. When the headlands are completed, press the Enable snap button.

## Farm Works Mate X2 Reference Guide

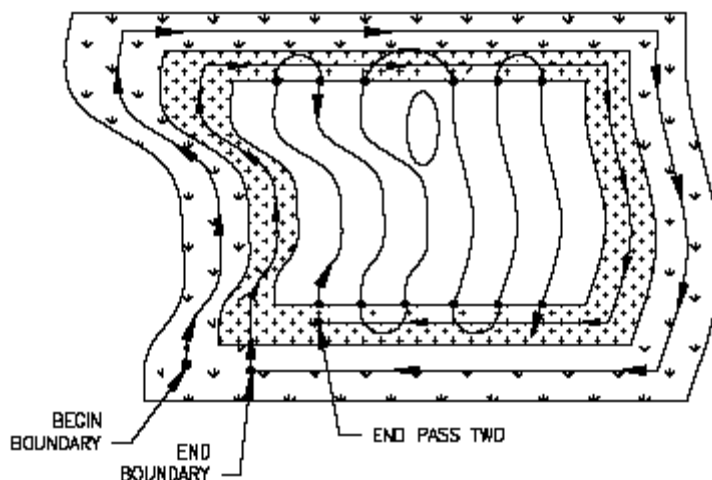

- **Spiral:** Guidance based on an outside boundary that continues to work towards the center of a field. Swath #1 begins after “Begin Boundary” is pressed. Continue to drive around the boundary of the field (GM will automatically record the path driven for the boundary area). Press “End Boundary” when the first boundary pass is complete (GM will automatically “End Boundary” if its position is within one boom width from the “Begin Boundary” point). Guidance for Swath 2 will be one swath width to the inside of the original boundary. “Swath +” and “Swath -“ buttons will be present after the boundary has been closed. If “Swath +” is pressed guidance will be given to the next swath towards the inside of the field. If “Swath -“ is pressed guidance will be given to the next swath towards the outside of the field. When at the end of Swath #2, user must press “Swath +” in order to initiate guidance for Swath #3, etc.

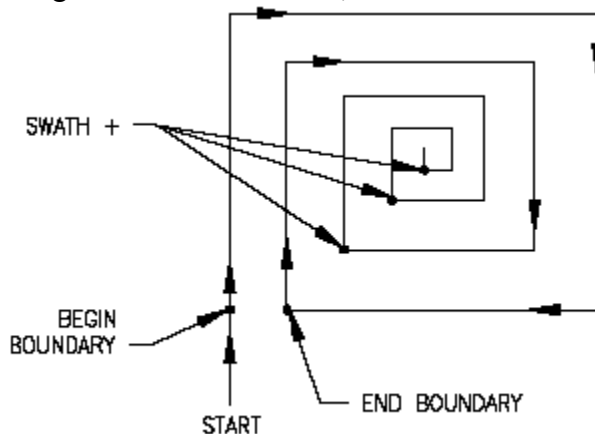

- **One Step:** Guidance for straight back and forth swathing, with guidance on the initial pass. While moving in the direction of the reference swath, press the “Set A” button. This sets the Start mark to the current position and the End mark ahead by four swath widths in the direction of the present Course over Ground. Guidance and offset indicators are shown immediately. Continue driving the reference swath. If offset errors are showing, press the “Set B” button to reset the



**Maximum HDOP** – This option allows you to filter positions and minimizes the occurrence of logging distant points if GPS signal is lost. The recommended setting for maximum HDOP is 25.

**Honor NMEA Checksum** – Check this box to throw out any points that have an incorrect Checksum.

### **What does that message mean at the bottom of my Site Mate screen?**

There are 4 possible messages you can see at the bottom of your Site Mate screen:

1. **Actual GPS Coordinates** - This tells you that you are receiving a GPS signal and you are ready to use Site Mate.
2. **Unable to Open Comm Port for GPS data** - This means that something is accessing the current port selected within the GPS Settings.
  - a. Double check your GPS Settings. Go to the Config tab – Settings – GPS Settings. Make sure the correct port is selected here.
  - b. If the correct port is selected, what else has been connected through this port? Sometimes external keyboards, other GPS programs, Active Sync, or other external hardware devices can be accessing the port even though it is no longer connected.

Possible Solutions:

- Soft reset the hand held and go directly to Site Mate.
- Change the GPS Settings within the program or hardware drivers.
- Remove any drivers or programs used for other devices through Start – Settings – System – Remove Programs on the hand held device.

3. **No GPS Data Received** – This can mean one of several things.

- a. GPS receiver is not receiving power.

Note: if using an IFB box with a non-Raven receiver, you will need a special power adaptor to power the IFB and in return, send GPS signal to the hand held.

- b. NMEA – The GPS receiver must be configured to output NMEA strings. The GPS receiver also must output NMEA 0183 strings. At a minimum, it needs to output the GGA and VTG strings.
- c. Incorrect Baud Rate is selected within the GPS Settings. Double check the GPS Settings within Site Mate. You can also use the Auto-Baud feature. If

## Farm Works Mate X2 Reference Guide

there is a GPS signal present, Site Mate will search all of the comm ports and baud rates until it finds it.

4. Cabling Issue. If the incorrect cabling is being used, Site Mate will display this message as well.
5. No Message at all. Occasionally, the area at the bottom of Site Mate will be blank. If this happens:
  - a. Go to the Config tab – Advanced Logging Options. If an IFB box or implement switch is not being used, make sure the box is not checked beside Enable Implement Switch.

### **Why is nothing being logged in Site Mate?**

Several things can prohibit Site Mate from logging data. If you encounter this problem, try the following:

1. GPS Signal – Make sure you have a good GPS Signal. Go to the Data tab within Site Mate. How many satellites are being used? What is the signal quality?
2. Manual Logging – Make sure Manual logging is not activated. (If a Log button is appearing after you tap Go, manual logging is turned on.)
3. Zoom Status – If you are zoomed too far out or are scrolled off of the screen, you will not be able to view your data. Use the zoom tools to zoom in on your current position.
  - a. Check/uncheck the options to auto scroll and auto scroll and zoom on the log menu.
  - b. Tap on the zoom in / zoom all buttons at the bottom of the map tab.
4. Check the settings on the Config tab.
  - a. Minimum GPS Quality – Go to Settings – GPS Settings – Comm tab to check this setting.
    - i. Set this at 1. This will allow Site Mate to log data as long as you are receiving a GPS signal.
    - ii. If this is set at 2, data will not be logged unless you are receiving differential (WAAS).

## Farm Works Mate X2 Reference Guide

- b. Enable Implement Switch – Go to Advanced – Advanced Logging Options on the Config tab to check this setting. If you are using Site Mate Basic, it will be found under Advanced – Implement Switch.
  - i. If you are not using an implement switch, this option should not be enabled.
  - ii. If you are using an implement switch, make sure the appropriate option is selected beneath this setting.
  - iii. If using an implement switch, make sure the logic is correct. If it logs while the implement is up or off, check the option to reverse the implement switch logic.
- c. Recording Interval – Go to Logging – Auto Logging on the Config tab
  - i. Enter the minimum time and distance required for logging data. If both requirements are not met, data will not be logged.
  - ii. A typical setting is 1 second and 10 feet.
- d. Display – Select the appropriate mapping option (path, points, or boundary) below Display on the Config tab to check this setting.
  - i. Boundary or Points – Make sure the appropriate option is selected here. If wanting to log the actual path or boundary only, check the actual box. If using an offset and the offset path or boundary is all that is wanted, only check offset. If you want to log both, check both boxes. Also verify the line width and color.
  - ii. Points – Enlarge the point size to see if previously logged points become visible.

### **Why do I only see a line or a blank screen on the map tab of Site Mate?**

**Maximum HDOP** – To reduce the chances of this happening, change this setting to 25.

Occasionally GPS receivers can lose GPS signal, causing Site Mate to lose position. If this happens, even for a moment, your position in Site Mate will bounce to the coordinates 0,0. Once the GPS receiver acquires GPS signal again, Site Mate will locate your position and bounce back to the current location. When this happens, Site Mate will draw a line to or log a point at this 0,0 coordinate, creating a stray line or an unwanted point far away from your desired map.

## VRA Controller Setup

### *Supported Controller Types*

The program supports a wide range of variable rate controllers. The list of supported controllers is always growing. If you do not see your controller on this list, contact your software provider and we will work to add your controller to a future version.

AGCO Falcon	
AGCO Fieldstar	
AL 2000 Yield	
Amazone Amaspray+ ASD	
Amazone Amados+ ASD	
Amazone Amatron II	
Amazone Amatron IIA	
Amazone Amatron+	
Axiomatic	For manure application
Bogballe	
DGH Counter	
Dickey John	Dry, Liquid, or NH3
EM38	
Farm Scan	
Flexi-Coil	
Grain Scan	
Green Seeker	
Hardi International	
Hardi Mustang	
Hiniker	
John Blue	
Kverneland	
LH-Agro	Sprayer, Fertilizer, Drill or Slurry Spreader
Micro-Trak	
Micro-Trak Yield	
Mid-Tech	Granular or Liquid
New Leader	Including Mark III & IV
Raven	Versions A-H or J, Granular or Liquid
Rawson	
RTS On/Off	
Squibb-Taylor	
TeeJet	
Veris 3-Speed	
Veris EC	

## Farm Works Mate X2 Reference Guide

The Controller tab in the Variable Rate Setup box is used for entering additional information required for several of the compatible controllers. Some controllers do not require additional information to be entered on the Controller tab. These include Amazone, Axiomatic, EM38, Farm Scan, Hardi International, Hardi Mustang, John Blue, Kverneland, Micro-Trak, RTS On/Off, Squibb-Taylor, and Veris EC.

The required information is listed below by controller:

### **AL2000 Yield**

Enter the Combine Flow Delay, Start Delay, and Stop Delay. Consult your combine owner's manual for this information.

Check the box for Log raw monitor data (.dbg file) if desired.

### **Bogballe**

Select the correct version – BC2002 or BC2003

### **DGH Counter**

Select Event Counter or Current Meter. Enter the pulses/gallon and the number of positions to use in smoothing (1-10).

### **Dickey John**

Select the Channel Type – dry, liquid, or NH3

### **Flexicoil**

Enter the number of channels and select the channel you will be controlling with Site Mate. Place the red check mark next to the desired channel.

### **Grain Scan**

Enter the Baud Rate for the controller and check the box next to Create raw text output file (dbg) if desired.

### **Green Seeker**

Check the box next to *Raw text file output* (.txt) if desired.

### **Hiniker**

Check the box next to Use Snap Shot Reply for versions 2.03 and higher.

### **Micro-Trak Yield**

Enter the weight of the crop per bushel as well as the Dry Moisture %. Check the box next to Raw GeoMarker Output (.dbg file), if desired.

### **Mid-Tech**

Select whether the application is granular or liquid and the correct Datalink for your controller. If using Ver 5, make sure the correct baud rate is selected. Make sure the red check mark is next to the channel that you will be controlling with Farm Site Mate.

### **New Leader**

Enter the Nominal Rate. The Nominal Rate is an average of the rates that are included on the Rx map.

### **Raven**

Enter the number of channels. Select the channel that you will be controlling by tapping in the Var. column next to the appropriate channel. The red check mark should be displayed next to the channel that you will be controlling. Select whether this application will be liquid or granular as well as the correct Revision.

### **Rawson**

Enter the Nominal Rate. This is the average of the rates that are to be applied. Select the Step percentage. This value must match the Step that is being used on the controller itself.

### **TeeJet**

Select the model – 844 or 854. Users will also select the desired Units.

### **Veris 3-Speed**

Enter the Nominal Rate. This is the average of the rates that are to be applied. Also, enter the Step percentage. This value must match the controller.